



SPIELFREIE KUPPLUNGEN

METALLBALGKUPPLUNGEN
ELASTOMERKUPPLUNGEN
GELENKKUPPLUNGEN
Distanzkupplungen
SCHALENKUPPLUNGEN
SCHLITZKUPPLUNGEN
KLEMMRINGE

KBK – Das Unternehmen

Unser Unternehmen KBK Antriebstechnik GmbH wurde am 02.07.2003 gegründet. Die Idee von qualitativ hochwertigen, austauschkompatiblen Produkten zu günstigen Preisen hat uns seitdem einen ständig wachsenden Stamm zufriedener Kunden in 52 Ländern beschert. In unseren Produkten steckt eine über 30-jährige Erfahrung in Entwicklung und Produktion von Kupplungen und Spannsätzen, welche wir gepaart mit kompetenter Beratung, Service und fachlicher Kompetenz gerne für eine erfolgreiche Zusammenarbeit mit unseren Kunden einbringen. Heute steht die Marke KBK für Innovation, höchste Qualität und kürzeste Lieferzeiten. Weltweit termingerechte Lieferung ist auch durch die optimale Lage unseres Unternehmens zum Frankfurter Rhein-Main-Flughafen sowie die ideale Anbindung an das Straßennetz gewährleistet. Nutzen Sie alle unsere Stärken sowie unsere große Motivation, alle Geschäftspartner mehr als zufrieden zu stellen und sparen Sie Ihrem Unternehmen damit Zeit und Geld ein.

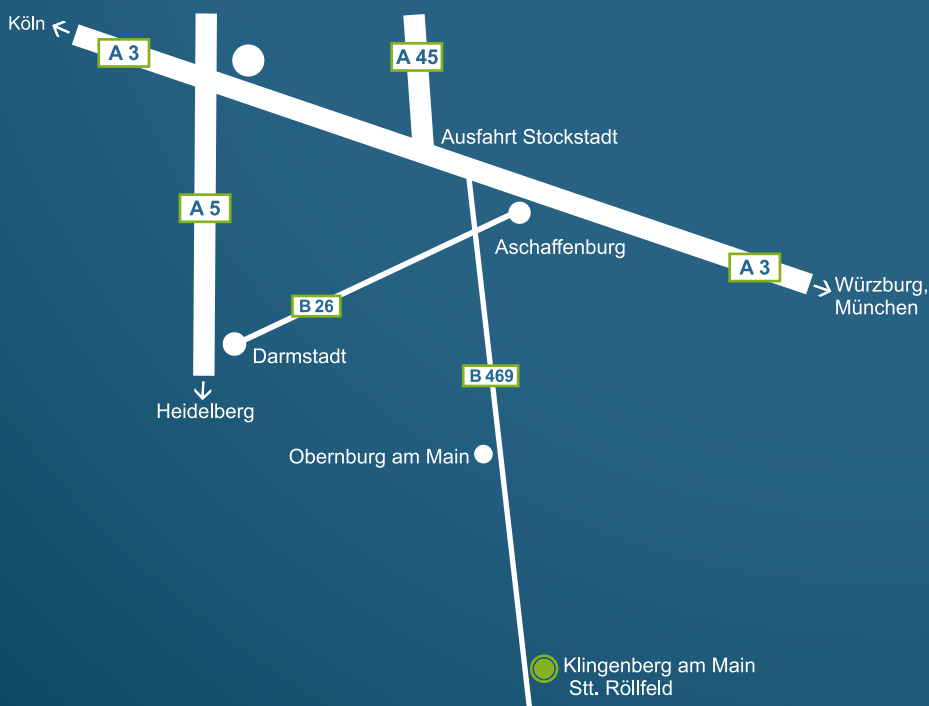

Inhalt

Übersicht Miniatur-Metallbalgkupplungen

KB1 - mit Stiftschraube 0,05 bis 30 Nm	Seite 5
KB1P - axial steckbar, mit Stiftschraube 0,5 bis 10 Nm	Seite 6
KB2 - mit Klemmnabe 0,1 bis 10 Nm	Seite 7
KB2H - in Halbschalenausführung 0,5 bis 10 Nm	Seite 8
KB2P - axial steckbar, mit Klemmnabe 0,5 bis 10 Nm	Seite 9
KB2VA - mit Edelstahl-Klemmnabe 0,1 bis 10 Nm	Seite 10
KB3 - mit Spreiznabe 0,5 bis 10 Nm	Seite 11
KB3P - axial steckbar, mit Spreiznabe 0,5 bis 10 Nm	Seite 12

Übersicht Metallbalgkupplungen

KB4 - mit Klemmnabe 18 bis 1400 Nm	Seite 14 / 15
KB4AL - mit Klemmnabe 80 bis 500 Nm	Seite 16
KB4C - mit Klemmnabe, Kompaktversion 18 bis 500 Nm	Seite 17
KB4F - zum Flanschanbau 18 bis 1400 Nm	Seite 18
KB4FA - mit Adapterflansch 18 bis 1400 Nm	Seite 19
KB4H - in Halbschalenausführung 18 bis 1400 Nm	Seite 20
KB4HC - in Halbschalenausführung 18 bis 500 Nm	Seite 21
KB4K - mit Klemmnabe 40 bis 1500 Nm	Seite 22
KB4LV - längenverstellbare Ausführung	Seite 23
KB4P - axial steckbar 18 bis 500 Nm	Seite 24
KB4VA - mit Edelstahl-Klemmnabe 18 bis 500 Nm	Seite 25
KB5 - mit Innenkonus 18 bis 5000 Nm	Seite 26
KB6 - mit Außenkonus 18 bis 5000 Nm	Seite 27
KB6P - axial steckbar, mit Außenkonus 18 bis 500 Nm	Seite 28
KB7 - in Flanschausführung 18 bis 5000 Nm	Seite 29
KB8 - mit Spreiznabe 18 bis 500 Nm	Seite 30
KB8P - axial steckbar, mit Spreiznabe 18 bis 500 Nm	Seite 31

Übersicht Elastomerkupplungen

KBE1 - mit Stiftschraube Größe 5 bis 55	Seite 33
KBE2 - mit Klemmnabe Größe 5 bis 19	Seite 34
KBE2 - mit Klemmnabe Größe 24 bis 55	Seite 35
KBE2C - mit Klemmnabe, Kompaktversion Größe 7 bis 48	Seite 36
KBE2H - in Halbschalenausführung Größe 14 bis 55	Seite 37
KBE2HC - in Halbschalenausführung Größe 14 bis 48	Seite 38
KBE2D - doppelkardanisch mit Klemmnabe Größe 7 bis 48	Seite 39
KBE3 - mit Außenkonus Größe 14 bis 55	Seite 40
KBE3C - Kompaktversion mit Außenkonus Größe 14 bis 55	Seite 41
KBE4 - mit Spreiznabe Größe 14 bis 48	Seite 42

Inhalt

Übersicht spielfreie Zahnkränze zu Elastomerkupplungen	Seite 44
Übersicht spielbehaftete Zahnkränze zu Elastomerkupplungen	Seite 45
Übersicht Gelenkkupplungen	Seite 46
GK - Linearkupplung mit Gewinde 200 bis 13000 N	Seite 47
GK-T - mit Klemmnabe 2 bis 250 Nm	Seite 48
GK-TH - in Halbschalenausführung 5 bis 250 Nm	Seite 49
Übersicht Distanzkupplungen	Seite 50
DRE - Halbschalenausführung mit Elastomerstern	Seite 51
DRB - in Halbschalenausführung mit Bälgen	Seite 52
Übersicht Schlitzkupplungen	Seite 53
KBFK - Schlitzkupplung mit Klemmnabe	Seite 54
KBFH - Schlitzkupplung in Halbschalenausführung	Seite 55
Übersicht Schalenkupplungen	Seite 56
KBST - Schalenkupplung, einfach geschlitzt	Seite 57/58
KBST-VA - Schalenkupplung, einfach geschlitzt, Edelstahl	Seite 59/60
KBST-G - Schalenkupplung, geteilt	Seite 61/62
KBST-G-VA - Schalenkupplung, geteilt, Edelstahl	Seite 63/64
Übersicht Klemmringe	Seite 65
KR - Klemmring, geschlitzt	Seite 66
KR-G - Klemmring, geteilt	Seite 67

Miniatürkupplungen

KB1 | 05 ~ 300

Miniatür-Metallbalgkupplung
mit Stiftschraube



S. 6

KB1P | 5 ~ 100

Miniatür-Metallbalgkupplung
axial steckbar, mit Stiftschraube



S. 7

KB2 | 1 ~ 100

Miniatür-Metallbalgkupplung
mit Klemmnabe



S. 8

KB2H | 5 ~ 100

Miniatür-Metallbalgkupplung
in Halbschalenausführung



S. 9

KB2P | 5 ~ 100

Miniatür-Metallbalgkupplung
axial steckbar, mit Klemmnabe



S. 10

KB2VA | 1 ~ 100

Miniatür-Metallbalgkupplung
mit Edelstahl-Klemmnabe



S. 11

KB3 | 5 ~ 100

Miniatür-Metallbalgkupplung
mit Spreiznabe



S. 12

KB3P | 5 ~ 100

Miniatür-Metallbalgkupplung
axial steckbar, mit Spreiznabe



S. 13

Miniatur-Metallbalgkupplung

mit Stiftschraube

optional
lasergeschweißt
optional komplett
in Edelstahl

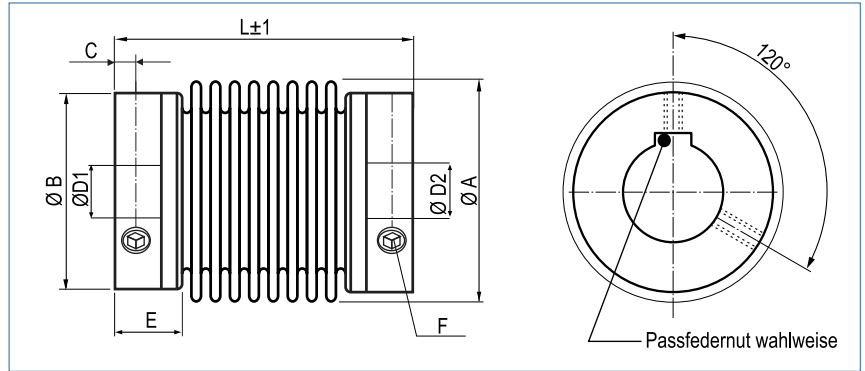

Bestellbeispiel

KB1 / 45 - 40 - 10 - 18 - (S)

Typ / Größe Länge L ØD1 (H7) ØD2 (H7) Optionen

Größe	Drehmoment TKN (Nm)	Abmessungen (mm)							Technische Daten							
		L Länge	Ø A Außen-durch-messer	D1/D2 Bohrungen (H7) von-bis	Ø B Naben durch-messer	C	E Naben-länge	F Schraube (ISO4029) TA (Nm)	Masse (g)	Massen-trägheits-moment J (g cm ²)	Federsteifigkeit			Versatz		
										Torsion CT (Nm/rad)	radial CR (N/mm)	axial CA (N/mm)	radial ΔKr (mm)	axial ΔKa (mm)	Winkel ΔKw (°)	
05	0.05	14	6.5	1-3	6.5	1.5	4	1x M2 0.35	1	0.1	50	6	9	0.1	0.4	1
1	0.1	23	10	1-4	10	2	6	1x M3 0.5	3	0.45	65	10	14	0.12	0.2	1.2
5	0.5	19	15	3-8	13.5	2	6	1x M3 0.5	4	1.3	260	43	13	0.1	0.2	1
		4.5							1.5	200	18	10	0.15	0.3	1.5	
		5							1.6	160	9	8	0.2	0.4	2	
10	1	21	15	3-8	13.5	2	6	1x M3 0.5	5.5	1.8	510	74	27	0.1	0.2	1
		6							2	380	31	20	0.15	0.3	1.5	
		7							2.3	310	16	16	0.2	0.4	2	
15	1.5	26	19	3-12	19	3	8	2x M4	10	6	750	59	15	0.1	0.3	1.5
		30		8#				1.5	12	7.4	700	20	9	0.15	0.4	2
20	2	22	24	3-14	21.5	3	6	2x M4	11	9.2	1500	67	12	0.15	0.3	1.5
		28		10#				13	12.6	1300	21	11	0.2	0.4	1.5	
		32		1.5				15	13.5	1050	11	9	0.25	0.5	2	
45	4.5	40	32	6-19	29	4	12	2x M6	44	68	6500	168	32	0.1	0.3	1.5
		48		13#				3	50	79	4200	41	20	0.2	0.5	2
100	10	45	40	6-24	36	4	12	2x M6	60	150	8100	120	27	0.15	0.4	1.5
		55		17#				3	79	210	6800	29	17	0.3	0.6	2
180	18	63	45	10-28	44	7	19.5	2xM8	100	339	20000	205	50	0.2	0.5	1.5
		71						20	150	396	15000	82	36	0.25	0.5	2
300	30	65	56	10-34	54	9	24.5	2xM8	180	945	38000	720	50	0.15	0.6	1.5
		73						20	200	958	28000	225	28	0.25	1	2

Drehzahl	max. 15000 min ⁻¹
Material	Balg - Edelstahl, Größe 05: Bronze Nabe - Aluminium
Nabe	Bohrungstoleranz: H7
Temperaturbereich	-30 °C ~ 120 °C
Passfedernut	wahlweise nach DIN 6885 größtmögliche Bohrung mit # gekennzeichnet

Miniatur-Metallbalgkupplung

axial steckbar, mit Stiftschraube

optional
lasergeschweißt
optional komplett
in Edelstahl

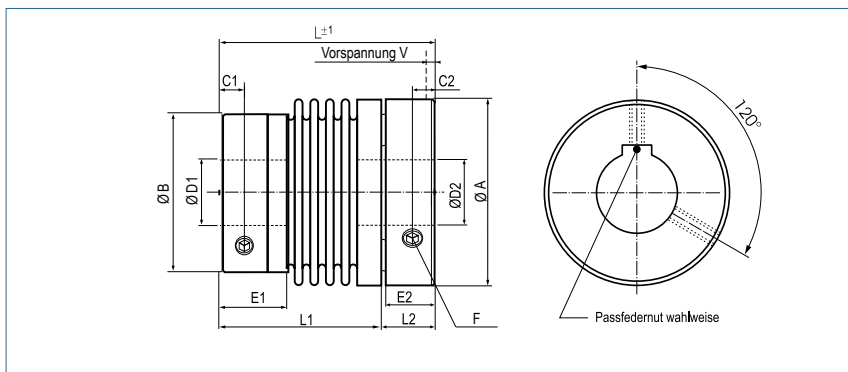

Bestellbeispiel

KB1P / 15 - 32 - 5 - 10 - D - (S)

Typ / Größe Länge L ØD1 (H7) ØD2 (H7) Steckung Optionen

Größe	Drehmoment TKN (Nm)	Abmessungen (mm)							Technische Daten								
		Länge	Ø A	Ø B	D1 Bohrung (H7) von-bis	D2 Bohrung (H7) von-bis	C1	C2	F Schraube (ISO4029) TA (Nm)	Masse (g)	Massenträgheitsmoment J (g cm ²)	Federsteifigkeit			Versatz		
			Stecknaben durchmesser	Stiftschrauben durchmesser							Torsion CT (Nm/rad)	radial CR (N/mm)	axial CA (N/mm)	radial Δ Kr (mm)	axial Δ Ka (mm)	Winkel Δ Kw (°)	
5	0.5	22	15.5	13.5	3-8	3-8	2	2	1xM3	5.9	1.9	260	43	13	0.1	0.2	1
		26								6.6	2.2	200	18	10	0.15	0.3	1.5
		30								7.4	2.4	160	9	8	0.2	0.4	2
10	1	24	15.5	13.5	3-8	3-8	2	2	1xM3	8.1	2.7	510	74	27	0.1	0.2	1
		28								8.8	2.9	380	31	20	0.15	0.3	1.5
		32								10.3	3.4	310	16	16	0.2	0.4	2
15	1.5	28	20	19	3-12	3-10	3	2.5	2xM4	14.7	8.8	750	59	15	0.1	0.3	1.5
		32			8#	7#				17.6	10.9	700	20	9	0.15	0.4	2
20	2	27	25	21.5	3-14	3-14	3	2.5	2xM4	16.2	13.5	1500	67	12	0.15	0.3	1.5
		33			19.1	17.5				1300	21	11	0.2	0.4	1.5		
		37			1.5	22				19.9	1050	11	9	0.25	0.5	2	
45	4.5	44	32.5	29	6-19	6-16	4	4	2xM6	64.7	100	6500	168	32	0.1	0.3	1.5
		52			3	73.5				116	4200	41	20	0.2	0.5	2	
100	10	50	40.5	36	6-24	6-25	4	4	2xM6	88.2	220.5	8100	120	27	0.15	0.4	1.5
		60			3	116.1				308.7	6800	29	17	0.3	0.6	2	

Drehzahl	max. 15000 min ⁻¹
Material	Balg - Edelstahl Nabe - Aluminium
Nabe	Bohrungstoleranz: H7
Temperaturbereich	-30 °C ~ 120 °C
Passfedernut	wahlweise nach DIN 6885 größtmögliche Bohrung mit # gekennzeichnet

Größe	Abmessungen (mm)					
	E1	E2	L1	L2	L3	V
5	6	4	17	5	9	0.5
			21			
			25			
10	6	4	19	5	9	0.5
			23			
			27			
15	8	5	22	6	11	0.5
			26			
20	6	5	21	6	11	0.5
			27			
			31			
45	12	8	35	9	16	0.5
			43			
100	12	8	41	9	17	1
			51			

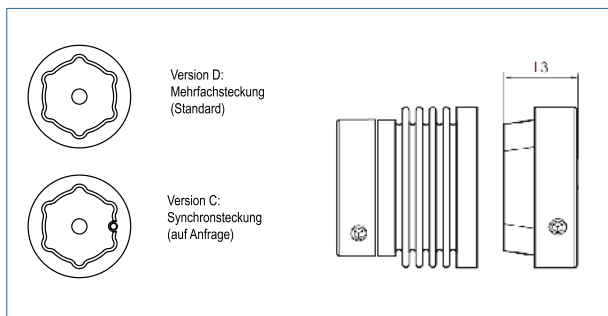

Miniatur-Metallbalgkupplung

mit Klemmnabe

optional
lasergeschweißt
optional komplett
in Edelstahl

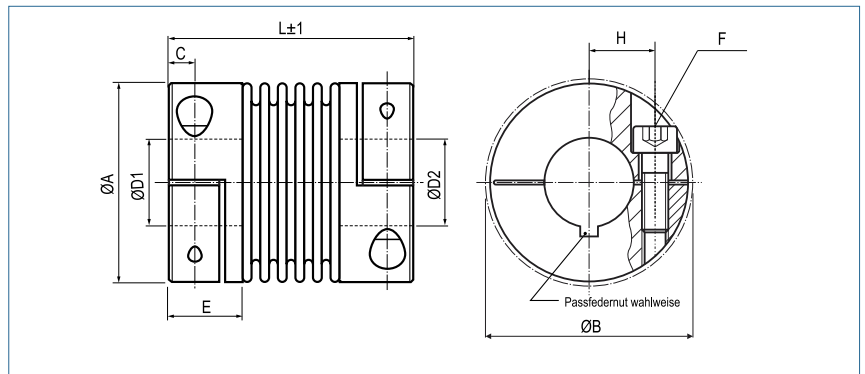

Bestellbeispiel

KB2 / 45 - 50 - 10 - 16 - (S)

Typ / Größe

Länge
L

ØD1
(H7)

ØD2
(H7)

Optionen

Größe	Drehmoment TKN (Nm)	Abmessungen (mm)								Technische Daten										
		L	Ø A	D1/D2	H	C	Ø B	E	F	Masse (g)	Massen- trägheits- moment J (g cm ²)	Federsteifigkeit			Versatz					
		Länge	Außen- durch- messer	Bohrun- gen (H7) von-bis			Stör Ø	Naben- länge	Schraube (ISO4762) TA (Nm)			Torsion CT (Nm/rad)	radial CR (N/mm)	axial CA (N/mm)	radial ΔKr (mm)	axial ΔKa (mm)	Winkel ΔKw (°)			
1	0.1	25	10	1-4	3.4	2	11	7	M1.6 0.1	3	0.5	65	10	14	0.12	0.2	1.2			
		21		3-8					M2	7.5	2.7	260	43	13	0.1	0.2	1			
5	0.5	25	15.5	8#	5.2	2.5	17.5	7	0.43	7.8	2.8	200	18	10	0.15	0.3	1.5			
		28																8#		
		23		3-8					M2	9	3.1	510	74	27	0.1	0.2	1			
10	1	26	15.5	8#	5.2	2.5	17.5	7	0.43	9.3	3.4	380	31	20	0.15	0.3	1.5			
		31																8#		
15	1.5	26	20	3-10	7	3	21	8,5	M2.5	13	8	750	59	15	0.1	0.3	1.5			
		31		10#								0.85	15	9.3	700	20	9	0.15	0.4	2
20	2	32		3-14	9	3.5	27	11	M3	29	24	1500	67	12	0.15	0.3	1.5			
		38	25	14#									32	27	1300	21	11	0.2	0.4	1.5
		42											2	33	29	1050	11	9	0.25	0.5
45	4.5	41	32.5	6-18	12	5	34	13	M4	61	100	6500	168	32	0.1	0.3	1.5			
		50		18#								3.5	67	112	4200	41	20	0.2	0.5	2
100	10	47		6-25	15.5	5	41.5	13,5	M4	86	233	8100	120	27	0.15	0.4	1.5			
		57	40.5	25#								4.5	106	290	6800	29	17	0.3	0.6	2



Drehzahl	max. 15000 min ⁻¹
Material	Balg - Edelstahl Nabe - Aluminium
Nabe	Bohrungstoleranz: H7
Temperaturbereich	-30 °C ~ 120 °C
Passfedernut	wahlweise nach DIN 6885 größtmögliche Bohrung mit # gekennzeichnet

Miniatur-Metallbalgkupplung

in Halbschalenausführung

optional
lasergeschweißt
optional komplett
in Edelstahl

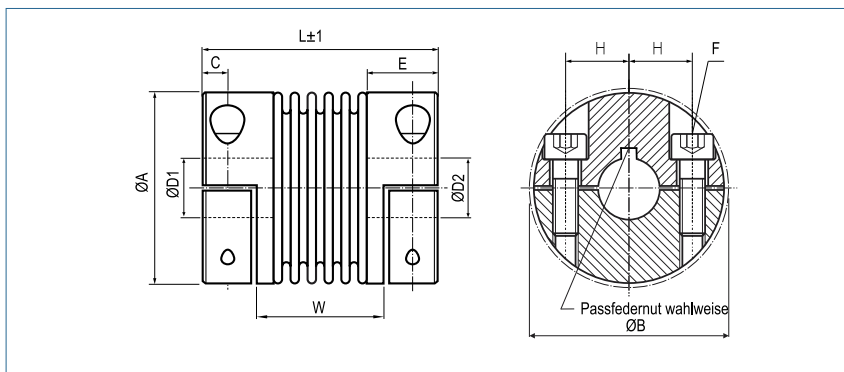

Bestellbeispiel

KB2H / 45 - 50 - 10 - 16 - (S)

Typ / Größe

Länge
L

ØD1
(H7)

ØD2
(H7)

Optionen

Größe	Drehmoment TKN (Nm)	Abmessungen (mm)									Technische Daten							
		L Länge	Ø A Außen- durch- messer	D1/D2 Bohrun- gen (H7) von~bis	H	C	ØB Stör Ø	E Naben- länge	W	F Schraube (ISO4762) TA (Nm)	Masse (g)	Massen- trägheits- moment J (g cm ²)	Federsteifigkeit			Versatz		
												Torsion CT (Nm/rad)	radial CR (N/mm)	axial CA (N/mm)	radial ΔKr (mm)	axial ΔKa (mm)	Winkel ΔKw (°)	
5	0.5	21	15.5	3-8	5.2	2.5	17.5	7	12	M2	7.5	2.7	260	43	13	0.1	0.2	1
		16							0.43	7.8	2.8	200	18	10	0.15	0.3	1.5	
		19								8.2	3	160	9	8	0.2	0.4	2	
10	1	23	15.5	3-8	5.2	2.5	17.5	7	14	M2	9	3.1	510	74	27	0.1	0.2	1
		17							0.43	9.3	3.4	380	31	20	0.15	0.3	1.5	
		22		10						3.7	310	16	16	0.2	0.4	2		
15	1.5	26	20	3-10	7	3	21	8.5	14.4	M2.5	13	8	750	59	15	0.1	0.3	1.5
		19.4		0.85					15	9.3	700	20	9	0.15	0.4	2		
20	2	32	25	3-14	9	3.5	27	11	18.4	M3	29	24	1500	67	12	0.15	0.3	1.5
		24.4							2	32	27	1300	21	11	0.2	0.4	1.5	
		28.4		33						29	1050	11	9	0.25	0.5	2		
45	4.5	41	32.5	6-18	12	5	34	13	24	M4	61	100	6500	168	32	0.1	0.3	1.5
		33		3.5					67	112	4200	41	20	0.2	0.5	2		
100	10	47	40.5	6-25	15.5	5	41.5	13.5	29	M4	86	233	8100	120	27	0.15	0.4	1.5
		39		4.5					106	290	6800	29	17	0.3	0.6	2		

Drehzahl	max. 15000 min ⁻¹
Material	Balg - Edelstahl Nabe - Aluminium
Nabe	Bohrungstoleranz: H7
Temperaturbereich	-30 °C ~ 120 °C
Passfedernut	wahlweise nach DIN 6885 größtmögliche Bohrung mit # gekennzeichnet

Miniatur-Metallbalgkupplung

axial steckbar, mit Klemmnabe

optional
lasergeschweißt
optional komplett
in Edelstahl

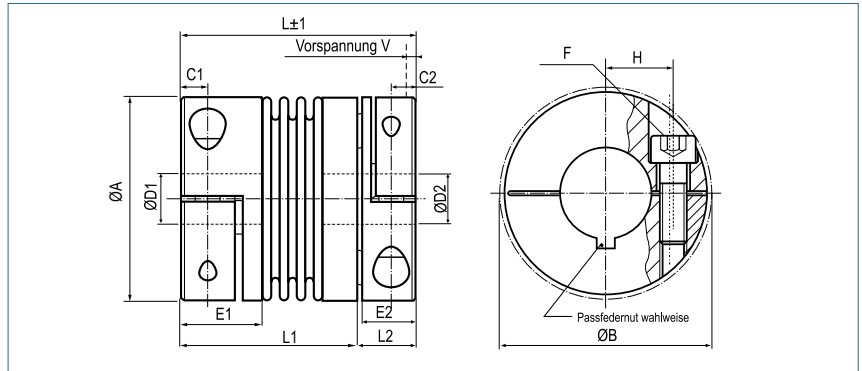

Bestellbeispiel

KB2P / 15 - 30 - 5 - 10 - D - (S)

Typ / Größe Länge L ØD1 (H7) ØD2 (H7) Steckung Optionen

Größe	Drehmoment TKN (Nm)	Abmessungen (mm)								Technische Daten								
		L Länge	Ø A Außen- durch- messer	Ø B Stör Ø	D1 Bohrung (H7) von-bis	D2 Bohrung (H7) von-bis	H	C1	C2	F Schraube (ISO4762) TA (Nm)	Masse (g)	Massen- trägheits- moment J (g cm ²)	Federsteifigkeit			Versatz		
												Torsion CT (Nm/rad)	radial CR (N/mm)	axial CA (N/mm)	radial Δ Kr (mm)	axial Δ Ka (mm)	Winkel Δ Kw (°)	
5	0.5	25	15.5	17.5	3-8	3-8	5.2	2.5	2.5	M2	8.7	3.1	260	43	13	0.1	0.2	1
		29			8#					9.1	3.3	200	18	10	0.15	0.3	1.5	
		32			0.43					9.6	3.5	160	9	8	0.2	0.4	2	
10	1	27	15.5	17.5	3-8	3-8	5.2	2.5	2.5	M2	10.5	3.6	510	74	27	0.1	0.2	1
		30			8#					10.8	3.9	380	31	20	0.15	0.3	1.5	
		32			0.43					11.7	4.3	310	16	16	0.2	0.4	2	
15	1.5	30	20	21	3-10	3-10	7	3	3	M2.5	15.2	9.3	750	59	15	0.1	0.3	1.5
		35			10#	7#				0.85	17.5	10.8	700	20	9	0.15	0.4	2
20	2	37	25	27	3-14	3-14	9	3.5	3.5	M3	33.8	27.8	1500	67	12	0.15	0.3	1.5
		43			14#	10#				2	38.5	33.6	1050	11	9	0.25	0.5	2
		47																
45	4.5	49	32.5	34	6-18	6-16	12	5	5	M4	71	116	6500	168	32	0.1	0.3	1.5
		58			18#	11#				3.5	78	129.9	4200	41	20	0.2	0.5	2
100	10	56	40.5	41.5	6-25	6-25	15.5	5	5	M4	100	270.3	8100	120	27	0.15	0.4	1.5
		66			25#	18#				4.5	123.5	336.4	6800	29	17	0.3	0.6	2

Drehzahl	max. 15000 min ⁻¹
Material	Balg - Edelstahl Nabe - Aluminium
Nabe	Bohrungstoleranz: H7
Temperaturbereich	-30 °C ~ 120 °C
Passfedernut	wahlweise nach DIN 6885 größtmögliche Bohrung mit # gekennzeichnet

Größe	Abmessungen (mm)					
	E1	E2	L1	L2	L3	V
5	7	6	18	7	11	0.5
			22			
			25			
10	7	6	20	7	11	0.5
			23			
			25			
15	8.5	6.5	22.5	7.5	12.5	0.5
			27.5			
20	11	10	26	11	16	0.5
			32			
			36			
45	13	12	36	14	20	0.5
			45			
100	13.5	12	43	14	21	1
			53			

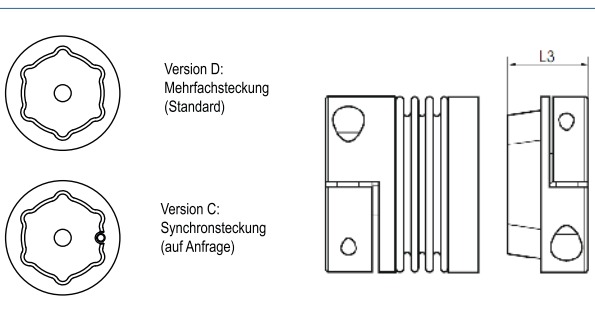

Miniatur-Metallbalgkupplung

mit Edelstahl-Klemmnabe

optional
lasergeschweißt

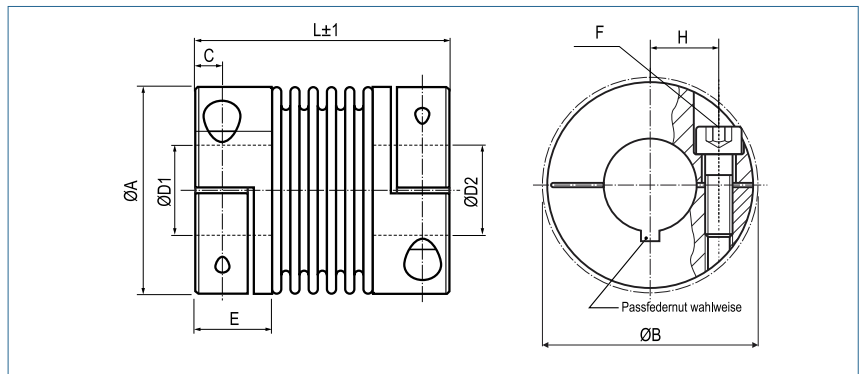

Bestellbeispiel

KB2 / 45 - 50 - 10 - 16 - VA/VAW

Typ / Größe Länge L ØD1 (H7) ØD2 (H7) Edelstahl / Edelstahl geklebt / lasergeschweißt

Größe	Drehmoment TKN (Nm)	Abmessungen (mm)								Technische Daten							
		L Länge	Ø A Außen-durch-messer	D1/D2 Bohrungen (H7) von-bis	H	C	Ø B Stör Ø	E Naben-länge	F Schraube (ISO4762) TA (Nm)	Masse (g)	Massen-trägheits-moment J (g cm ²)	Federsteifigkeit			Versatz		
											Torsion CT (Nm/rad)	radial CR (N/mm)	axial CA (N/mm)	radial ΔKr (mm)	axial ΔKa (mm)	Winkel ΔKw (°)	
1	0.1	25	10	1-4	3.4	2	11	7	M1.6 0.1	7	1	65	10	14	0.12	0.2	1.2
		21		3-8					M2	18	5.9	260	43	13	0.1	0.2	1
5	0.5	25	15.5	8#	5.2	2.5	17.5	7	0.43	18	6.2	200	18	10	0.15	0.3	1.5
		19		6.6					160	9	8	0.2	0.4	2			
		23		6.8					510	74	27	0.1	0.2	1			
10	1	26	15.5	8#	5.2	2.5	17.5	7	0.43	20	7.5	380	31	20	0.15	0.3	1.5
		21		8.1					310	16	16	0.2	0.4	2			
		31															
15	1.5	26	20	3-10	7	3	21	8,5	M2.5	36	18	750	59	15	0.1	0.3	1.5
		0.85		38					21	700	20	9	0.15	0.4	2		
20	2	32	25	3-14	9	3.5	27	11	M3	70	53	1500	67	12	0.15	0.3	1.5
		73		60					1300	21	11	0.2	0.4	1.5			
		75		64					1050	11	9	0.25	0.5	2			
45	4.5	41	32.5	6-18	11.5	5	34	13	M4	133	220	6500	168	32	0.1	0.3	1.5
		13		3.5					139	246	4200	41	20	0.2	0.5	2	
100	10	47	40.5	6-25	15.5	5	41.5	13,5	M4	244	513	8100	120	27	0.15	0.4	1.5
		13,5		4.5					261	638	6800	29	17	0.3	0.6	2	

Drehzahl	max. 15000 min ⁻¹
Material	Balg - hochelastischem Edelstahl Nabe - Edelstahl
Nabe	Bohrungstoleranz: H7
Temperaturbereich	VA -30 °C ~ 120 °C (geklebt) VAW -30 °C ~ 250 °C (lasergeschweißt)
Passfedernut	wahlweise nach DIN 6885 größtmögliche Bohrung mit # gekennzeichnet

Miniatur-Metallbalgkupplung

mit Spreiznabe

optional
lasergeschweißt
optional komplett
in Edelstahl

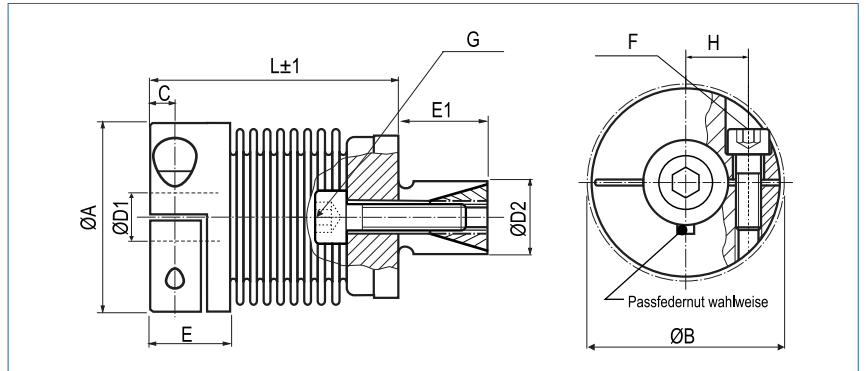

Bestellbeispiel

KB3 / 45 - 36 - 10 - 18 - (S)

Typ / Größe Länge L ØD1 (H7) ØD2 (f7) Optionen

Größe	Drehmoment TKN (Nm)	Abmessungen (mm)										Technische Daten							
		L Länge	Ø A Außen-durch-messer	D1 Bohrung (H7) von-bis	D2 Spreiz-dorn (f7) von-bis	Ø B Stör Ø	H	C	E	E1	F/G Schraube (ISO4762) TA (Nm)	Masse (g)	Massen-trägheits-moment J (g cm ²)	Federsteifigkeit			Versatz		
														Torsion CT (Nm/rad)	radial CR (N/mm)	axial CA (N/mm)	radial ΔKr (mm)	axial ΔKa (mm)	Winkel ΔKw (°)
5	0.5	20	15.5	3-8	8-12	17,5	5.2	2.5	7	8	M2/M3	12.8	2.9	260	43	13	0.1	0.2	1
		24		8#							0.3/1	13.2	3.1	200	18	10	0.15	0.3	1.5
		27		8#							0.3/1	13.5	3.2	160	9	8	0.2	0.4	2
10	1	22	15,5	3-8	8-12	17,5	5.2	2.5	7	8	M2/M3	14.1	3.3	510	74	27	0.1	0.2	1
		26		8#							0.3/1	14.6	3.4	380	31	20	0.15	0.3	1.5
		30		8#							0.3/1	15.3	3.6	310	16	16	0.2	0.4	2
15	1.5	25	20	3-10	10-14	21	7	3	8,5	12	M2.5/M4	27.2	11	750	59	15	0.1	0.3	1.5
		29		10#							0.8/3	29.3	12	700	20	9	0.15	0.4	2
20	2	28	25	3-14	10-16	27	9	3.5	11	12	M3/M4	40.1	25	1500	67	12	0.15	0.3	1.5
		34		14#							1/3	43.2	29	1300	21	11	0.2	0.4	1.5
		38		14#							1/3	49.1	30	1050	11	9	0.25	0.5	2
45	4.5	36	32.5	6-18	14-20	34	12	5	13	16	M4/M5	86.5	98	6500	168	32	0.1	0.3	1.5
		44		18#							3/5.9	92.9	110	4200	41	20	0.2	0.5	2
100	10	41	40.5	6-25	16-22	41,5	15.5	5	13,5	20	M4/M6	135	235	8100	120	27	0.15	0.4	1.5
		51		25#							3/10	154	292	6800	29	17	0.3	0.6	2

Drehzahl	max. 15000 min ⁻¹
Material	Balg - Edelstahl Klemmnabe - Aluminium Spreiznabe - Stahl
Nabe	Bohrungstoleranz: H7
Temperaturbereich	-30 °C ~ 120 °C
Passfedernut	wahlweise nach DIN 6885 größtmögliche Bohrung mit # gekennzeichnet

Miniatur-Metallbalgkupplung

axial steckbar, mit Spreiznabe

optional
lasergeschweißt
optional komplett
in Edelstahl

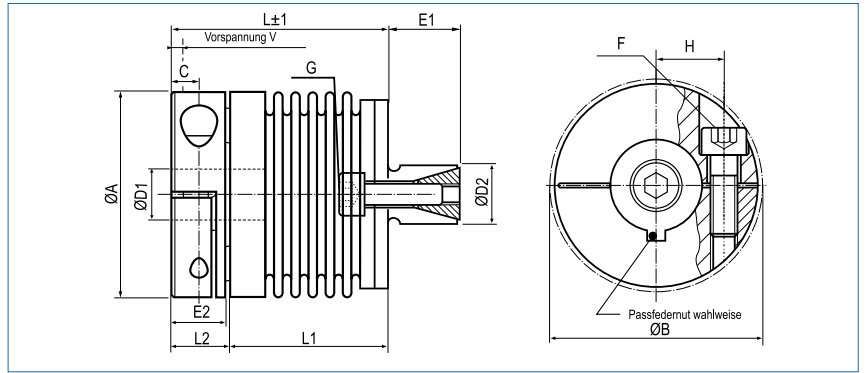

Bestellbeispiel

KB3P / 15 - 29 - 5 - 10 - D - (S)

Typ / Größe Länge L ØD1 (H7) ØD2 (f7) Steckung Optionen

Größe	Drehmoment TKN (Nm)	Abmessungen (mm)								Technische Daten							
		L Länge	Ø A Außen- durch- messer	Ø B Stör Ø	D1 Bohrung (H7) von-bis	D2 Spreiz- dorn (f7) von-bis	H	C	F/G Schraube (ISO4762) TA (Nm)	Masse (g)	Massen- trägheits- moment J (g cm ²)	Federsteifigkeit			Versatz		
											Torsion CT (Nm/rad)	radial CR (N/mm)	axial CA (N/mm)	radial Δ Kr (mm)	axial Δ Ka (mm)	Winkel Δ Kw (°)	
5	0.5	24	15.5	17.5	3-8	8-12	5.2	2.5	M2/M3	14.9	3.4	260	43	13	0.1	0.2	1
		28							15.4	3.6	200	18	10	0.15	0.3	1.5	
		31							15.8	3.7	160	9	8	0.2	0.4	2	
10	1	26	15.5	17.5	3-8	8-12	5.2	2.5	M2/M3	16.4	3.8	510	74	27	0.1	0.2	1
		30							17	4	380	31	20	0.15	0.3	1.5	
		34							17.8	4.2	310	16	16	0.2	0.4	2	
15	1.5	29	20	21	3-10	10-14	7	3	M2.5/M4	31.7	12.8	750	59	15	0.1	0.3	1.5
		7#			0.85/3				34.1	14	700	20	9	0.15	0.4	2	
20	2	33	25	27	3-14	10-16	9	3.5	M3/M4	46.7	29.1	1500	67	12	0.15	0.3	1.5
		39			50.3				33.8	1300	21	11	0.2	0.4	1.5		
		43			57.2				34.9	1050	11	9	0.25	0.5	2		
45	4.5	43	32.5	34	6-16	14-20	12	5	M4/M5	100.7	114.1	6500	168	32	0.1	0.3	1.5
		11#			3.5/5.9				108.1	128	4200	41	20	0.2	0.5	2	
100	10	49	40.5	41.5	6-25	16-22	15.5	5	M4/M6	157.1	273.5	8100	120	27	0.15	0.4	1.5
		59			4.5/10				179.3	339.9	6800	29	17	0.3	0.6	2	

Drehzahl	max. 15000 min ⁻¹
Material	Balg - Edelstahl Klemmnabe - Aluminium Spreiznabe - Stahl
Nabe	Bohrungstoleranz: H7
Temperaturbereich	-30 °C ~ 120 °C
Passfedernut	wahlweise nach DIN 6885 größtmögliche Bohrung mit # gekennzeichnet

Size	Dimensions (mm)					
	E1	E2	L1	L2	L3	V
5	8	6	17	7	11	0.5
			21			
			24			
10	8	6	19	7	11	0.5
			23			
			27			
15	12	6.5	21.5	7.5	12.5	0.5
			25.5			
20	12	10	22	11	16	0.5
			28			
			32			
45	16	12	30	13	20	0.5
			38			
100	20	12	36	13	21	1
			46			

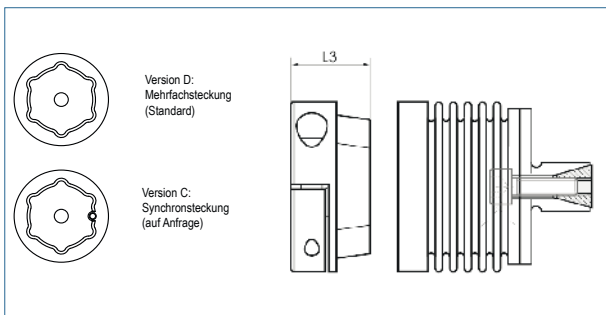

Metallbalgkupplungen

KB4 | 18 ~ 1400

Metallbalgkupplung
mit Klemmnabe



S. 16

KB4AL | 80 ~ 500

Metallbalgkupplung
mit Klemmnabe



S. 17

KB4C | 18 ~ 500

Metallbalgkupplung
kompakt mit Klemmnabe



S. 18

KB4F | 18 ~ 1400

Metallbalgkupplung
zum Flanschbau



S. 19

KB4FA | 18 ~ 1400

Metallbalgkupplung
mit Adapterflansch



S. 20

KB4H | 18 ~ 1400

Metallbalgkupplung
in Halbschalenausführung



S. 21

KB4HC | 18 ~ 500

Metallbalgkupplung
in Halbschalenausführung



S. 22

KB4K | 40 ~ 1500

Metallbalgkupplung
mit Klemmnabe



S. 23

KB4LV | 18 ~ 500

Metallbalgkupplung
längenverstellbare Ausführung



S. 24

KB4P | 18 ~ 500

Metallbalgkupplung
axial steckbar



S. 25

KB4VA | 18 ~ 500

Metallbalgkupplung
mit Edelstahl-Klemmnabe



S. 26

KB5 | 18 ~ 5000

Metallbalgkupplung
mit Innenkonus



S. 27

Metallbalgkupplungen

KB6 | 18 ~ 5000

Metallbalgkupplung
mit Außenkonus



S. 28

KB6P | 18 ~ 500

Metallbalgkupplung
Flanschausführung



S. 29

KB7 | 18 ~ 5000

Metallbalgkupplung
Flanschausführung



S. 30

KB8 | 18 ~ 500

Metallbalgkupplung
mit Spreiznabe



S. 31

KB8P | 18 ~ 500

Metallbalgkupplung
axial steckbar, mit Spreiznabe



S. 32

Metallbalgkupplung

mit Klemmnabe

optional
lasergeschweißt
optional komplett
in Edelstahl

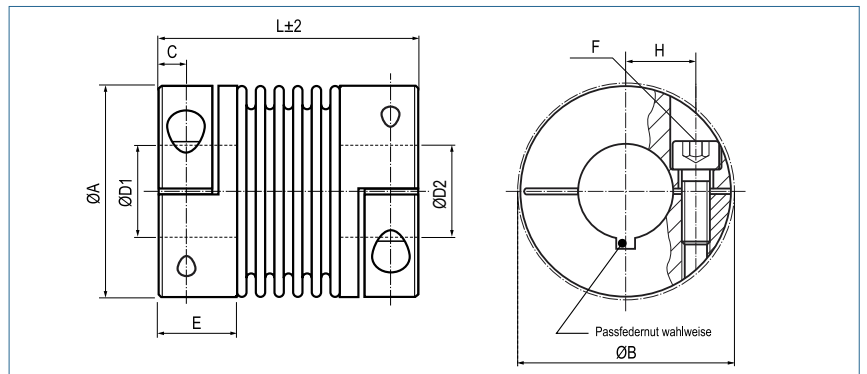

Bestellbeispiel

KB4 / 60 - 89 - 12 - 32 - (S)

Typ / Größe Länge L ØD1 (H7) ØD2 (H7) Optionen

Größe	Drehmoment TKN (Nm)	Abmessungen (mm)								Technische Daten								
		L Länge	Ø A Außen- durch- messer	D1/D2 Bohrungen (H7) von-bis	H	C	E	B Stör Ø	F Schraube (ISO4762) TA (Nm)	Masse (kg)	Massen- trägheits- moment J (g m²)	Federsteifigkeit			Versatz			max Drehzahl min-1
											Torsion CT 10³ (Nm/rad)	radial CR (N/mm)	axial CA (N/mm)	radial ΔKr (mm)	axial ΔKa (mm)	Winkel ΔKw (°)		
18	18	63	45	10-25.4	17	5.5	19.5	47.4	M5	0.1	0.04	20	205	50	0.2	0.5	1.5	12800
		71							8	0.15	0.05	15	82	36	0.25	0.5	2	12800
30	30	65	56	10-32	20	7.5	24.5	56.4	M6	0.3	0.15	38	720	50	0.15	0.6	1.5	10300
		73		15					0.32	0.16	28	225	28	0.25	1	2	10300	
60	60	79	66	12-35	23	10	29	66	M8	0.5	0.33	75	1150	90	0.15	0.6	1.5	8700
		89							40	0.6	0.36	50	340	50	0.25	1	2	8700
80	80	91	82	14-44	28	11	33.5	82.9	M10	2.3	2.3	128	1200	80	0.2	0.5	1.5	6900
		102							84	2.4	2.4	75	400	50	0.25	0.8	2	6900
150	150	91	82	19-44	28	11	33.5	82.9	M10	2.3	2.5	155	2020	145	0.2	0.5	1.5	6900
		102							84	2.4	2.6	105	595	85	0.25	0.8	2	6900
200	200	101	90	22-47	31	13	38	90.8	M12	2.6	3.3	175	2500	145	0.2	0.5	1.5	6400
		113							125	2.7	3.5	120	460	82	0.25	0.8	2	6400
300	300	105	110	30-60	40	13	38	110	M12	4.3	7.6	502	6300	280	0.2	0.5	1.5	6000
		116							145	4.4	7.8	285	1400	145	0.25	0.8	2	6000
500	500	112	122	35-70	42	15	42	122	M12	5.5	13.5	690	7790	100	0.2	0.5	1.5	5000
		123							145	5.6	13.7	320	970	85	0.25	1	2	5000
800	800	168	157	40-80	55	22.5	55	170.3	2xM20 400	14.3	56.9	1270	700	275	0.2	0.8	1.8	5000
1400	1400	168	157	50-80	55	22.5	55	170.3	2xM20 470	14.8	57.7	1270	700	275	0.2	0.8	1.8	5000

Material	Balg - Edelstahl Nabe - Größe 18 - 60: Aluminium Nabe - ab Größe 80: Stahl
Nabe	Bohrungstoleranz: H7
Temperaturbereich	-30 °C ~ 120 °C Größe 800/1400: -30 °C ~ 250 °C
Passfedernut	wahlweise nach DIN 6885 größtmögliche Bohrung mit # gekennzeichnet

Metallbalgkupplung in Aluminiumausführung

mit Klemmnabe

optional
lasergeschweißt
optional komplett
in Edelstahl

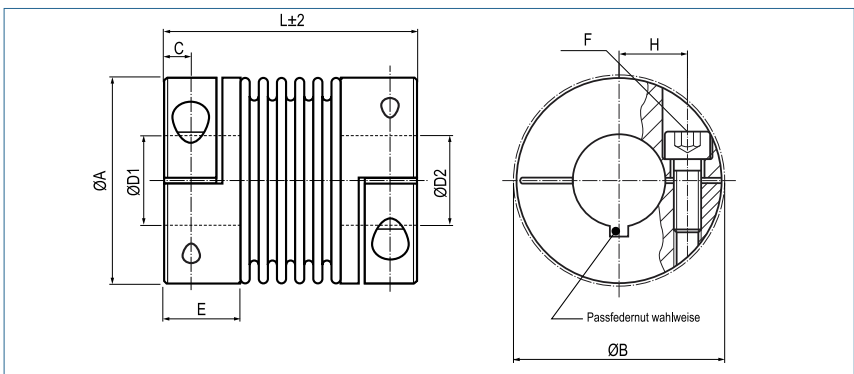

Bestellbeispiel

KB4AL / 80 - 91 - 15 - 20 - (S)

Typ / Größe

Länge
L

ØD1
(H7)

ØD2
(H7)

Optionen

Größe	Drehmoment TKN (Nm)	Abmessungen (mm)							Technische Daten									
		L Länge	Ø A Außen- durch- messer	D1/D2 Bohrungen (H7) von-bis	H	C	E	F Stör Ø	Masse (kg)	Massen- trägheits- moment J (g m ²)	Federsteifigkeit			Versatz			max Dreh- zahl min-1	
							Schraube (ISO4762) TA (Nm)			Torsion CT 10 ³ (Nm/rad)	radial CR (N/mm)	axial CA (N/mm)	radial ΔKr (mm)	axial ΔKa (mm)	Winkel ΔKw (°)			
80	80	91	82	12-44	28	11	33.5	82.9	M10	0.8	0.90	128	1200	80	0.2	0.5	1.5	6900
		84							0.85	0.95	75	400	50	0.25	0.8	2	6900	
150	150	91	82	14-44	28	11	33.5	82.9	M10	0.9	1.0	155	2020	145	0.2	0.5	1.5	6900
		84							0.95	1.05	105	595	85	0.25	0.8	2	6900	
200	200	101	90	16-47	31	13	38	90.8	M12	1.17	1.49	175	2500	145	0.2	0.5	1.5	6400
		125							1.21	1.57	120	460	82	0.25	0.8	2	6400	
300	300	105	110	20-60	40	13	38	110	M12	1.62	3.28	502	6300	280	0.2	0.5	1.5	6000
		145							1.66	3.37	285	1400	145	0.25	0.8	2	6000	
500	500	112	122	25-70	42	15	42	122	M12	2.4	6.4	690	7790	100	0.2	0.5	1.5	5000
		145							2.5	6.7	320	970	85	0.25	1.0	2	5000	



Material	Balg - Edelstahl Nabe - Aluminium
Nabe	Bohrungstoleranz: H7
Temperaturbereich	-30 °C ~ 120 °C
Passfedernut	wahlweise nach DIN 6885

Metallbalgkupplung kompakt

mit Klemmnabe

optional
lasergeschweißt
optional komplett
in Edelstahl

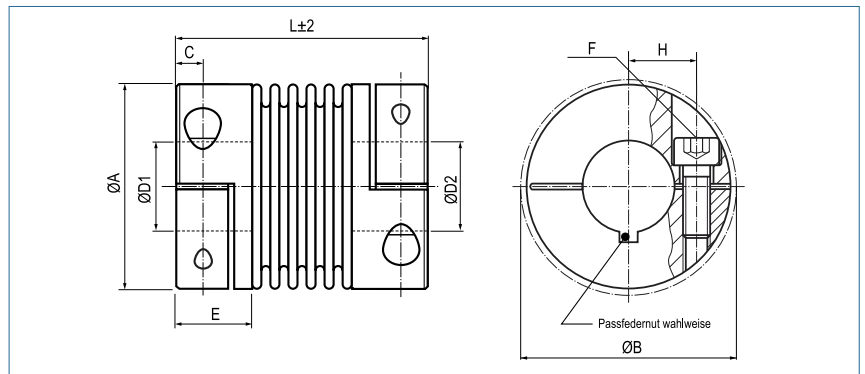

Bestellbeispiel

KB4C / 60 - 67 - 12 - 32 - (S)

Typ / Größe

Länge
L

ØD1
(H7)

ØD2
(H7)

Optionen

Größe	Drehmoment TKN (Nm)	Abmessungen (mm)								Technische Daten								
		L Länge	Ø A Außen- durch- messer	D1/D2 Bohrungen (H7) von-bis	H	C	E	B Stör Ø	F Schraube (ISO4762) TA (Nm)	Masse (kg)	Massen- trägheits- moment J (g m²)	Federsteifigkeit			Versatz			max Dreh- zahl min-1
											Torsion CT 10³ (Nm/rad)	radial CR (N/mm)	axial CA (N/mm)	radial ΔKr (mm)	axial ΔKa (mm)	Winkel ΔKw (°)		
18	18	58	45	10-25.4	17	5.5	17.5	47.4	M5	0.07	0.03	20	205	50	0.2	0.5	1.5	12800
		66								8	0.12	0.04	15	82	36	0.25	0.5	2
30	30	58	56	10-32	20	7.3	21	56.4	M6	0.26	0.13	38	720	50	0.15	0.6	1.5	10300
		66		15					0.27	0.14	28	225	28	0.25	1	2	10300	
60	60	67	66	12-35	24	8.6	24	66.2	M8	0.38	0.28	75	1150	90	0.15	0.6	1.5	8700
		77							40	0.42	0.31	50	340	50	0.25	1	2	8700
80	80	78	82	12-44	28	9.8	27	82.9	M10	0.70	0.78	128	1200	80	0.2	0.5	1.5	6900
		89							84	0.76	0.85	75	400	50	0.25	0.8	2	6900
150	150	78	82	14-44	28	9.8	27	82.9	M10	0.73	0.82	155	2020	145	0.2	0.5	1.5	6900
		89							84	0.80	0.89	105	595	85	0.25	0.8	2	6900
200	200	83	90	16-47	31	10.8	29	90.8	M12	0.89	1.19	175	2500	145	0.2	0.5	1.5	6400
		94							125	0.95	1.27	120	460	82	0.25	0.8	2	6400
300	300	94	110	20-60	40	11.8	32.5	110	M12	1.37	2.74	502	6300	280	0.2	0.5	1.5	6000
		105							145	1.43	2.86	285	1400	145	0.25	0.8	2	6000
500	500	100	122	25-70	42	13.3	36	122	M12	1.81	4.45	690	7790	100	0.2	0.5	1.5	5000
		111							145	1.91	4.69	320	970	85	0.25	1	2	5000

Material	Balg - Edelstahl Nabe - Aluminium
Nabe	Bohrungstoleranz: H7
Temperaturbereich	-30 °C ~ 120 °C
Passfedernut	wahlweise nach DIN 6885 größtmögliche Bohrung mit # gekennzeichnet

Metallbalgkupplung

zum Flanschanbau

optional
lasergeschweißt
optional komplett
in Edelstahl

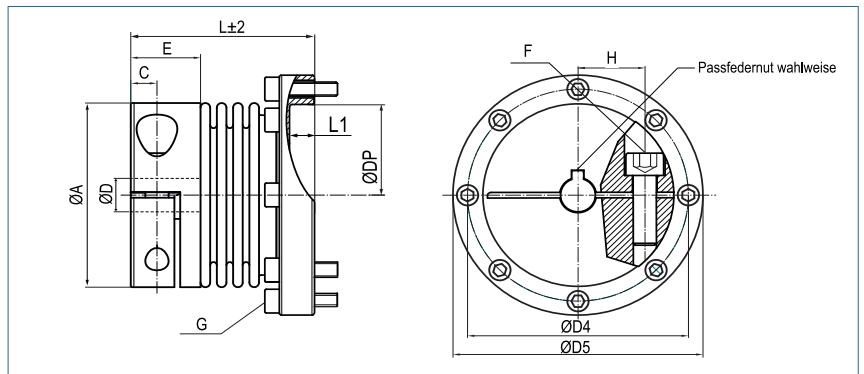

Bestellbeispiel

KB4F / 150 - 84 - 30 - 80

Typ / Größe

Länge
L

ØD
(H7)

DP

Größe	Drehmoment TKN (Nm)	Abmessungen (mm)											Technische Daten									
		L	L1	ØA	D1	H	C	E	D4	D5	DP	F	G	M (kg)	Massenträgheitsmoment J (g m²)	Federsteifigkeit			Versatz			max Drehzahl (min-1)
					Bohrung (H7) von-bis						H7	Schraube ISO4762 TA (Nm)	Schraube ISO4762 TA (nm)			Torsion CT 10³ (Nm/rad)	radial CR (N/mm)	axial CA (N/mm)	radial ΔKr (mm)	axial ΔKa (mm)	Winkel ΔKw (°)	
18	18	57	7.5	45	10-25.4	17	5.5	17.5	56.5	63.5	44	M5	8xM4	0.24	0.13	20	205	50	0.2	0.5	1.5	12800
		65										8	4.5	0.26	0.13	15	82	36	0.25	0.5	2	
30	30	60	8.5	56	10-32 30#	20	7.3	21	65	74	55	M6	8xM5	0.38	0.29	38	720	50	0.15	0.6	1.5	10300
		68										15	8	0.40	0.29	28	225	28	0.25	1.0	2	
60	60	61	8.5	66	12-35	23	8.6	24	76	86	65	M8	8xM5	0.57	0.56	75	1150	90	0.15	0.6	1.5	8700
		71										40	8	0.62	0.58	50	340	50	0.25	1.0	2	
150	150	73	8.5	82	14-44	28	9.8	27	94	104	80	M10	8xM6	0.87	1.33	155	2020	145	0.2	0.5	1.5	6900
		84										84	15	0.92	1.34	105	595	85	0.25	0.8	2	
300	300	86	10	110	30-60	40	11.8	32.5	120	132	105	M12	12xM6	1.78	4.39	502	6300	280	0.2	0.5	1.5	6000
		97										145	15	1.88	4.42	285	1400	145	0.25	0.8	2	
500	500	90	10	122	35-70	42	13.3	36	142	155	130	M12	12xM8	2.15	6.98	690	7790	100	0.2	0.5	1.5	5000
		101										145	40	2.30	7.09	320	970	85	0.25	1	2	
1400	1400	131	11	157	50-80	55	22.5	55	171	184	152	2xM20 470	16xM8 40	9.07	38.07	1270	700	275	0.2	0.8	1.8	5000

Material	Balg - Edelstahl Klemmnabe - bis Größe 500: hochfestes Aluminium Klemmnabe - Größe 1400: Stahl Flansche - Stahl
Nabe	Bohrungstoleranz: H7
Temperaturbereich	-30 °C ~ 120 °C -30 °C ~ 250 °C (Größe 1400)
Passfedernut	wahlweise nach DIN 6885 größtmögliche Bohrung mit # gekennzeichnet

Metallbalgkupplung

mit Adapterflansch

optional
lasergeschweißt
optional komplett
in Edelstahl

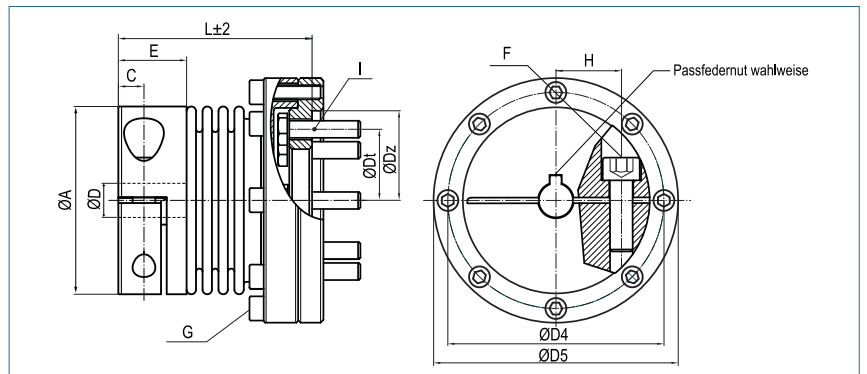

Bestellbeispiel **KB4FA / 150 - 79 - 30 - 63**

Typ / Größe

Länge
L

ØD
(H7)

Dt

Größe	Drehmoment TKN (Nm)	Abmessungen (mm)								Technische Daten								
		L Länge	Ø A Außen-durch-messer	D1 Bohrung (H7) von~bis	H	C	E	D4	F Schraube (ISO4762) TA (Nm)	Masse (kg)	Massen-trägheits-moment J (g m²)	Federsteifigkeit			Versatz			max Drehzahl (min-1)
											Torsion CT 10³ (Nm/rad)	radial CR (N/mm)	axial CA (N/mm)	radial ΔKr (mm)	axial ΔKa (mm)	Winkel ΔKw (°)		
18	18	63	45	10-25.4	17	5.5	17.5	56.5	M5	0.50	0.15	20	205	50	0.2	0.5	1.5	12800
		8							0.52	0.16	15	82	36	0.25	0.5	2		
30	30	61	56	10-32	20	7.3	21	65	M6	0.70	0.20	38	720	50	0.15	0.6	1.5	10300
		15		0.72					0.21	28	225	28	0.25	1.0	2			
60	60	68	66	12-35	23	8.6	24	76	M8	1.00	0.65	75	1150	90	0.15	0.6	1.5	8700
		40							1.05	0.68	50	340	50	0.25	1.0	2		
150	150	79	82	14-44	28	9.8	27	94	M10	1.65	1.30	155	2020	145	0.2	0.5	1.5	6900
		84							1.75	1.37	105	595	85	0.25	0.8	2		
300	300	90	110	30-60	40	11.8	32.5	120	M12	2.90	5.50	502	6300	280	0.2	0.5	1.5	6000
		145							3.00	5.62	285	1400	145	0.25	0.8	2		
500	500	100	122	35-70	42	13.3	36	142	M12	4.55	9.00	690	7790	100	0.2	0.5	1.5	5000
		145							4.70	9.15	320	970	85	0.25	1	2		
1400	1400	140	157	50-80	55	22.5	55	171	2xM20 470	10.50	45	1270	700	275	0.2	0.8	1.8	5000

Material	Balg - Edelstahl Klemmnabe - bis Größe 500: hochfestes Aluminium Klemmnabe - Größe 1400: Stahl Flansche - Stahl
Nabe	Bohrungstoleranz: H7
Temperaturbereich	-30 °C ~ 120 °C -30 °C ~ 250 °C (Größe 1400)
Passfedernut	wahlweise nach DIN 6885 größtmögliche Bohrung mit # gekennzeichnet

Größe	Abmessungen (mm)				
	G Schraube (ISO4762) / TA (Nm)	D5	Dt Teilkreis Getriebe	Dz H7	I Schraube (ISO4017) / TA (Nm)
18	8 x M4 / 4.5Nm	63.5	31.5	40	8 x M5 / 7.6Nm
30	8 x M5 / 8Nm	74	40	50	8 x M6 / 13.2Nm
60	8 x M5 / 8Nm	86	50	63	8 x M6 / 13.2Nm
150	8 x M6 / 15Nm	104	63	80	12 x M6 / 13.2Nm
300	12 x M6 / 15Nm	132	80	100	12 x M8 / 31.8Nm
500	12 x M8 / 40Nm	155	100	130	12 x M10 / 63Nm
1400	16 x M8 / 40Nm	184	125	160	12 x M10 / 63Nm

Metallbalgkupplung

in Halbschalenausführung

optional
lasergeschweißt
optional komplett
in Edelstahl

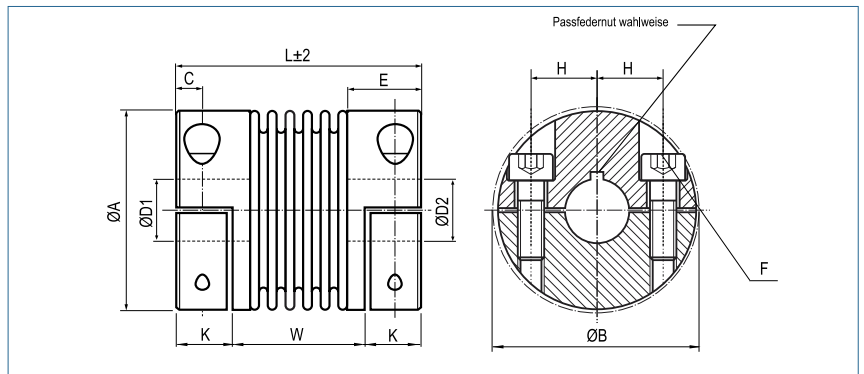

Bestellbeispiel

KB4H / 60 - 83 - 20 - 20 - (S)

Typ / Größe Länge L ØD1 (H7) ØD2 (H7) Optionen

Größe	Drehmoment TKN (Nm)	Abmessungen (mm)										Technische Daten								
		L Länge (±2)	Ø A Außen- durch- messer	D1/D2 Bohrungen (H7) von-bis	H	C	E	W	K	B	F	Schraube (ISO4762) TA (Nm)	Masse (kg)	Massen- trägheits- moment J (g m²)	Federsteifigkeit			Versatz		
														Torsion CT 10³ (Nm/rad)	radial CR (N/mm)	axial CA (N/mm)	radial ΔKr (mm)	axial ΔKa (mm)	Winkel ΔKw (°)	
18	18	63	45	10-25.4	17	5.5	19.5	37	13	47.4	M5	0.1	0.04	20	205	50	0.2	0.5	1.5	12800
		71						45						8	0.15	0.05	15	82	36	0.25
30	30	69	56	10-32	20	7.5	27	35	17	56.4	M6	0.3	0.14	38	720	50	0.15	0.6	1.5	10300
		77		30#				15			0.32	0.15	28	225	28	0.25	1	2	10300	
60	60	83	66	12-35	23	9.5	31	41	21	66.2	M8	0.5	0.28	75	1150	90	0.15	0.6	1.5	8700
		93						40			0.6	0.29	50	340	50	0.25	1	2	8700	
80	80	94	82	12-44	28	11	36	47	23.5	82.9	M10	0.9	0.65	128	1200	80	0.2	0.5	1.5	6900
		106						84			0.95	0.67	75	400	50	0.25	0.8	2	6900	
150	150	95	82	14-44	28	11	36	48	23.5	82.9	M10	0.9	0.82	155	2020	145	0.2	0.5	1.5	6900
		107						84			0.95	0.86	105	595	85	0.25	0.8	2	6900	
200	200	105	90	16-47	31	12.5	41	51	27	90.8	M12	1.3	2.2	175	2500	145	0.2	0.5	1.5	6400
		117						125			1.35	2.7	120	460	82	0.25	0.8	2	6400	
300	300	111	110	20-60	40	13	41	55	28	110	M12	1.8	4.2	502	6300	280	0.2	0.5	1.5	6000
		125						145			1.85	5.2	285	1400	145	0.25	0.8	2	6000	
500	500	133	122	25-70	42	15	51	62	35.5	122	M12	2.50	8.6	690	7790	100	0.2	0.5	1.5	5000
		146						145			2.51	9.3	320	970	85	0.25	1	2	5000	
800	800	168	157	40-80	55	22.5	66.5	77	45.5	168	M20	14.8	57.65	1270	700	275	0.2	0.8	1.8	5000
											400									
1400	1400	168	157	50-80	55	22.5	66.5	77	45.5	168	M20	15.3	58.70	1270	700	275	0.2	0.8	1.8	5000
											400									

Material	Balg - Edelstahl Nabe - bis Größe 500: Aluminium Nabe - ab Größe 800: Stahl
Nabe	Bohrungstoleranz: H7
Temperaturbereich	-30 °C ~ 120 °C Größe 800/1400: -30 °C ~ 250 °C
Passfedernut	wahlweise nach DIN 6885 größtmögliche Bohrung mit # gekennzeichnet

Metallbalgkupplung

in Halbschalenausführung, kompakt

optional
lasergeschweißt
optional komplett
in Edelstahl

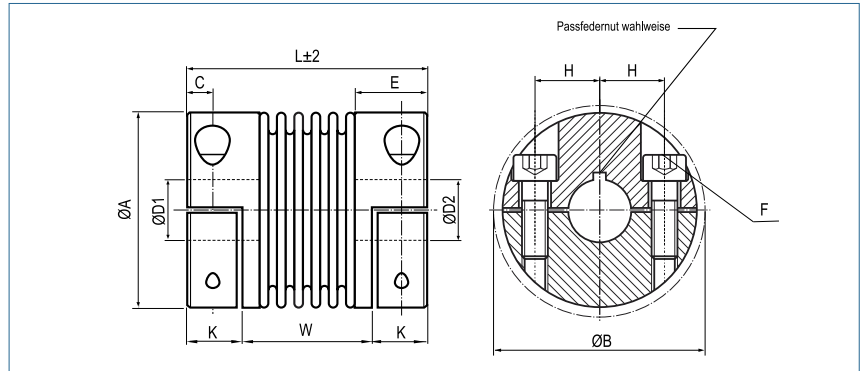

Bestellbeispiel

KB4HC / 60 - 67 - 20 - 20 - (S)

Typ / Größe

Länge
L

ØD1
(H7)

ØD2
(H7)

Optionen

Größe	Drehmoment TKN (Nm)	Abmessungen (mm)										Technische Daten								
		L Länge	Ø A Außen- durch- messer	D1/D2 Bohrungen (H7) von-bis	H	C	E	W	K	B Stör Ø	F Schraube (ISO4762) TA (Nm)	Masse (kg)	Massen- trägheits- moment J (g m²)	Federsteifigkeit			Versatz			max Dreh- zahl (min-1)
														Torsion CT 10³ (Nm/rad)	radial CR (N/mm)	axial CA (N/mm)	radial ΔKr (mm)	axial ΔKa (mm)	Winkel ΔKw (°)	
18	18	58	45	10-25.4	17	5.5	17.5	36	11	47.4	M5	0.07	0.03	20	205	50	0.2	0.5	1.5	12800
		66						44				8	0.12	0.04	15	82	36	0.25	0.5	2
30	30	58	56	10-32	20	7.3	21	31	13.5	56.4	M6	0.26	0.13	38	720	50	0.15	0.6	1.5	10300
		66		39				15			0.27	0.14	28	225	28	0.25	1	2	10300	
60	60	67	66	12-35	23	8.6	24	33	17	66.2	M8	0.38	0.28	75	1150	90	0.15	0.6	1.5	8700
		77						43			40	0.42	0.31	50	340	50	0.25	1	2	8700
80	80	78	82	12-44	28	9.8	27	42	18	82.9	M10	0.70	0.78	128	1200	80	0.2	0.5	1.5	6900
		89						53			84	0.76	0.85	75	400	50	0.25	0.8	2	6900
150	150	78	82	14-44	28	9.8	27	42	18	82.9	M10	0.73	0.82	155	2020	145	0.2	0.5	1.5	6900
		89						53			84	0.80	0.89	105	595	85	0.25	0.8	2	6900
200	200	83	90	16-47	31	10.8	29	43	20	90.8	M12	0.89	1.19	175	2500	145	0.2	0.5	1.5	6400
		94						54			125	0.95	1.27	120	460	82	0.25	0.8	2	6400
300	300	94	110	20-60	40	11.8	32.5	50	22	110	M12	1.37	2.74	502	6300	280	0.2	0.5	1.5	6000
		105						61			145	1.43	2.86	285	1400	145	0.25	0.8	2	6000
500	500	100	122	25-70	42	13.3	36	48	26	122	M12	1.81	4.45	690	7790	100	0.2	0.5	1.5	5000
		111						59			145	1.91	4.69	320	970	85	0.25	1	2	5000



Material	Balg - Edelstahl Nabe - Aluminium
Nabe	Bohrungstoleranz: H7
Temperaturbereich	-30 °C ~ 120 °C
Passfedernut	wahlweise nach DIN 6885 größtmögliche Bohrung mit # gekennzeichnet

Metallbalgkupplung

mit Klemmnabe

optional
lasergeschweißt
optional komplett
in Edelstahl

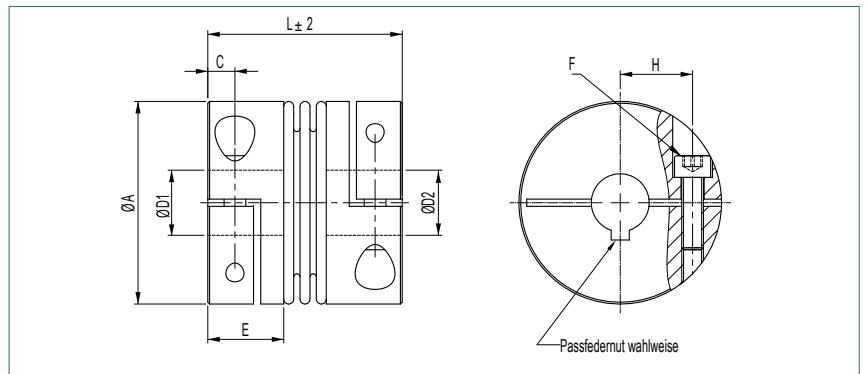

Bestellbeispiel

KB4K / 400 - 75 - 44 - 40 - (S)

Typ / Größe Länge L ØD1 (H7) ØD2 (H7) Optionen

Größe	Drehmoment TKN (Nm)	Abmessungen (mm)							Technische Daten								
		L	Ø A	D1/D2	H	C	E	F	Masse (kg)	Massenträgheitsmoment J (g m²)	Federsteifigkeit			Versatz			max Drehzahl min-1
Länge	Außen-durchmesser	Bohrungen (H7) von-bis				Schraube (ISO4762) TA (Nm)				Torsion CT 10³ (Nm/rad)	radial CR (N/mm)	axial CA (N/mm)	radial ΔKr (mm)	axial ΔKa (mm)	Winkel ΔKw (°)		
10	10	35	32.5	6-18	12	5	13	M4 3.5	0.06	0.008	9	1518	63	0.05	0.5	0.5	15000
20	20	39	40.5	6-25	15.5	5	13.5	M4 4.5	0.09	0.02	15	1208	65	0.05	0.5	0.5	15000
40	40	46	45	10-25.4	17	5.5	17.5	M5 8	0.07	0.04	35	3350	97	0.05	0.5	0.5	12800
80	80	55	56	12-32 30#	20	7.3	21	M6 15	0.26	0.14	53	6436	165	0.05	0.5	0.5	10300
200	200	60	66	16-35	23	8.6	23	M8 40	0.38	0.28	138*	12442	287	0.1	1	0.5	8700
400	400	75	82	32-44	28	9.8	27	M10 84	0.70	0.82	176	6815	338	0.1	1	0.5	6900
650	650	78	90	37-47	31	10.8	29	M12 125	0.89	1.19	230	7910	386	0.1	1.5	1	6400
1000	1000	84	110	42-60	40	11.8	32,5	M12 145	1.37	2.74	579	29096	756	0.1	1.5	1	6000
1500	1500	96	122	50-70	42	13.3	36	M12 145	1.81	4.45	693	20694	639	0.1	1.5	1	5000



Material	Balg - Edelstahl Nabe - Aluminium
Nabe	Bohrungstoleranz: H7
Temperaturbereich	-30 °C ~ 120 °C
Passfedernut	wahlweise nach DIN 6885 größtmögliche Bohrung mit # gekennzeichnet * Ausführung: 2-Wellen-Balg

Metallbalgkupplung

längenverstellbare Ausführung

optional
lasergeschweißt
optional komplett
in Edelstahl

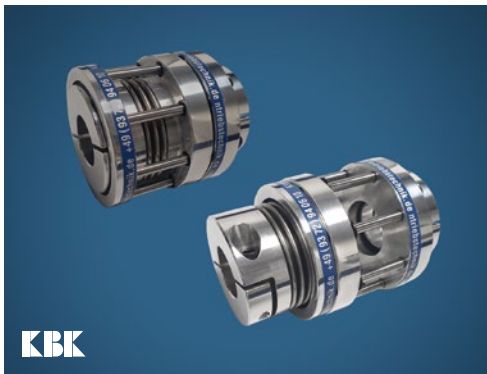

KBK

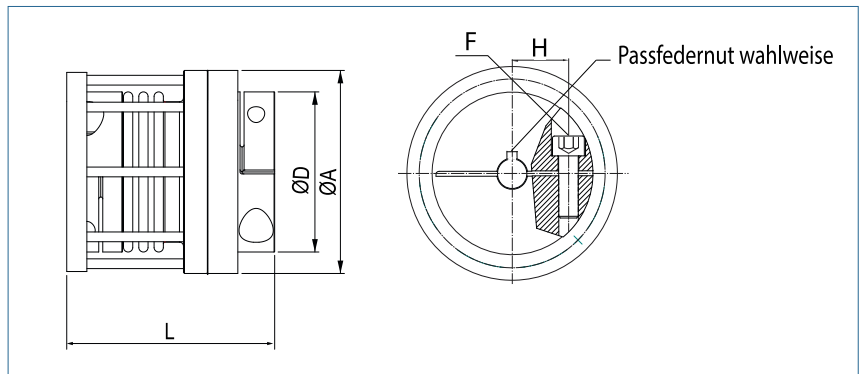

Bestellbeispiel

KB4LV / 60 - 87 - 12 - 32 - (S)

Typ / Größe

Länge
L

ØD1
(H7)

ØD2
(H7)

Optionen

Größe	Drehmoment TKN (Nm)	Abmessungen (mm)									Technische Daten								
		L Länge	L1 max. Länge	Ø D Nabendurchmesser	Ø A Außendurchmesser	D1/D2 Bohrungen (H7) von-bis	H	C	E	F Schraube ISO4762 TA (Nm)	Masse (kg)	Massenträgheitsmoment J (g m²)	Federsteifigkeit			Versatz			max Drehzahl min-1
												Torsion CT 10³ (Nm/rad)	radial CR (N/mm)	axial CA (N/mm)	radial ΔKr (mm)	axial ΔKa (mm)	Winkel ΔKw (°)		
18	18	69.5	100	45	63	10-25.4	17	5.5	17.5	M5 8	0.25	0.15	35	3350	97	0.1	0.5	0.5	12800
30	30	82.5	115	56	74	10-32 30#	20	7.3	21	M6 15	0.5	0.37	53	6436	165	0.1	0.5	0.5	10300
60	60	87	120	66	86	12-35	24	8.6	24	M8 40	0.78	3.88	138*	12442	287	0.15	1	0.5	8700
150	150	102	150	82	104	14-44	28	9.8	27	M10 84	1.1	1.56	176	6815	338	0.15	1	0.5	6900
300	300	119	179	110	132	20-60	40	11.8	32.5	M12 145	2.2	5.32	579	29096	756	0.15	1.5	1	6000
500	500	129.5	190	122	155	25-70	42	13.3	36	M12 145	3.25	10.14	693	20694	639	0.15	1.5	1	5000



Material Balg - Edelstahl
Nabe - Aluminium

Nabe Bohrungstoleranz: H7

Temperaturbereich -30 °C ~ 120 °C

Passfedernut wahlweise nach DIN 6885
größtmögliche Bohrung mit # gekennzeichnet
* Ausführung: 2-Wellen-Balg

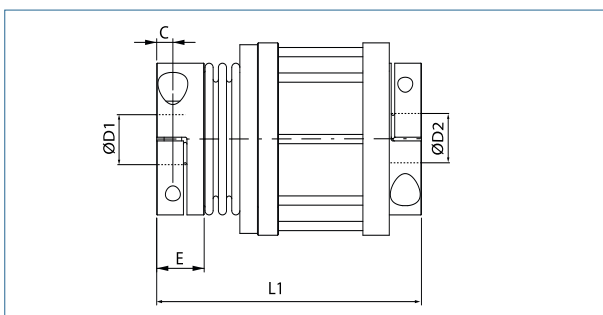

Metallbalgkupplung

axial steckbar, mit Klemmnabe

optional
lasergeschweißt
optional komplett
in Edelstahl

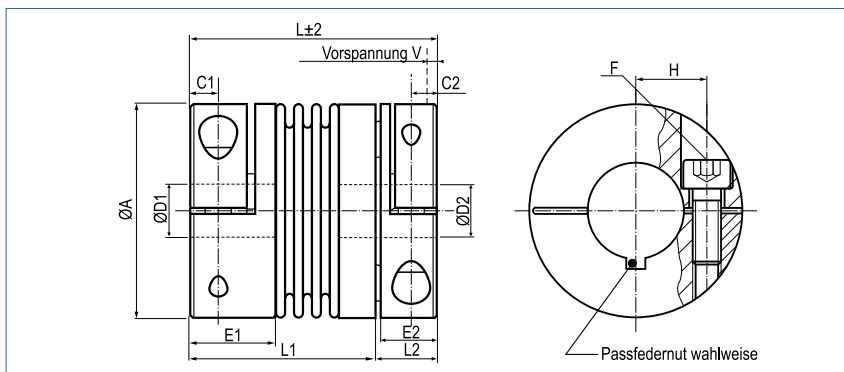
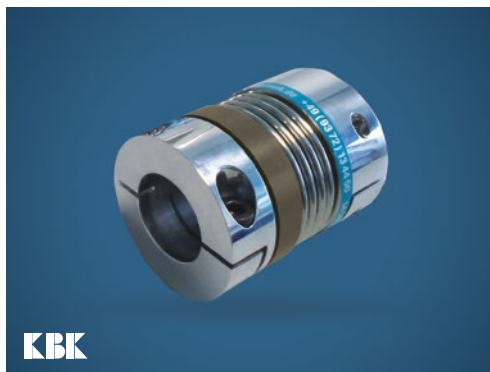

Bestellbeispiel

KB4P / 150 - 95 - 44 - 28 - D - (S)

Typ / Größe Länge L ØD1 (H7) ØD2 (H7) Steckung Optionen

Größe	Drehmoment TKN (Nm)	Abmessungen (mm)										Technische Daten								
		Länge	Ø A	D1/D2	H	C1	C2	E1	E2	B	F	Schraube (ISO4762) TA (Nm)	Masse (kg)	Massenträgheitsmoment J (g m²)	Torsion CT 10³ (Nm/rad)	radial CR (N/mm)	axial CA (N/mm)	radial ΔKr (mm)	axial ΔKa (mm)	Winkel ΔKw (°)
18	18	62	45	10-24	17	5.5	5.5	17.5	12	47.4	M5	0.14	0.05	20	205	50	0.2	0.5	1.5	12800
		70									8	0.19	0.06	15	82	36	0.25	0.5	2	
30	30	73	56	10-30	20	7.5	7.3	24.5	17	56.4	M6	0.29	0.14	38	720	50	0.15	0.6	1.5	10300
		81									15	0.31	0.15	28	225	28	0.25	1.0	2	
60	60	85	66	12-35	23	10	8.6	29	21	66	M8	0.47	0.33	75	1150	90	0.15	0.6	1.5	8700
		95									40	0.57	0.36	50	340	50	0.25	1.0	2	
80	80	95	82	12-44	28	11	9.8	33.5	21.5	82.9	M10	0.81	0.89	128	1200	80	0.2	0.5	1.5	6900
		106									84	0.90	0.99	75	400	50	0.25	0.8	2	
150	150	95	82	14-44	28	11	9.8	33.5	21.5	82.9	M10	0.91	1.08	155	2020	145	0.2	0.5	1.5	6900
		106									84	1.00	1.18	105	595	85	0.25	0.8	2	
200	200	105	90	16-47	31	13	10.8	38	24	90.8	M12	1.16	1.47	175	2500	145	0.2	0.5	1.5	6400
		117									125	1.26	1.67	120	460	82	0.25	0.8	2	
300	300	114	110	20-60	40	13	10.8	38	27	110	M12	1.68	3.33	502	6300	280	0.2	0.5	1.5	6000
		125									145	1.78	3.53	285	1400	145	0.25	0.8	2	
500	500	136	122	25-70	42	15	13.3	42	42	122	M12	2.50	6.21	690	7790	100	0.2	0.5	1.5	5000
		147									145	2.60	6.41	320	970	85	0.25	1.0	2	



Material	Balg – Edelstahl Nabe - hochfestes Aluminium
Nabe	Bohrungstoleranz: H7
Passfedernut	wahlweise nach DIN 6885
Temperaturbereich	-30 °C ~ 120 °C

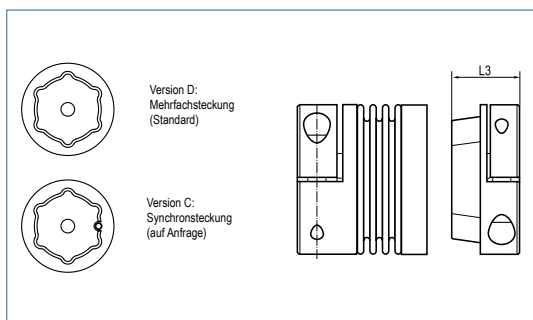

Größe	Abmessungen (mm)			
	L1	L2	L3	V
18	48	14	22	0.5-1.0
	56			
30	54	19	31	0.5-1.0
	62			
60	62	23	35	0.5-1.5
	72			
80	71.5	23.5	37.5	0.5-1.5
	82.5			
150	71.5	23.5	37.5	0.5-1.5
	82.5			
200	79	26	42	0.5-1.5
	91			
300	85	29	47	0.5-1.5
	96			
500	92	44	66	0.5-2.0
	103			

Metallbalgkupplung

mit Edelstahl-Klemmnabe

optional
lasergeschweißt

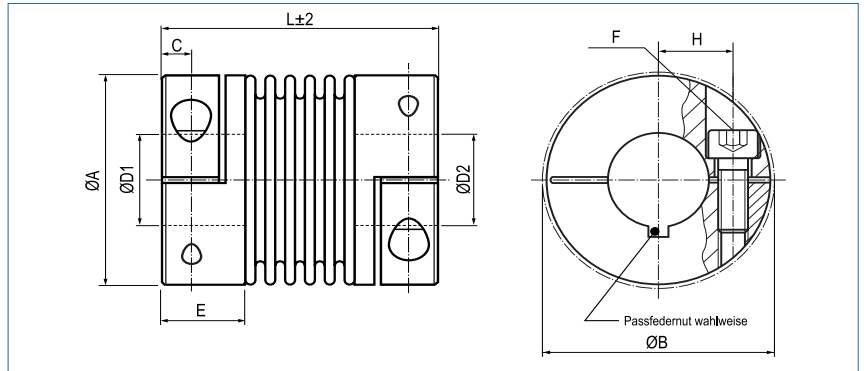

Bestellbeispiel

KB4 / 60 - 89 - 12 - 32 - VA/VAW

Typ / Größe Länge L ØD1 (H7) ØD2 (H7) Edelstahl / Edelstahl geklebt / lasergeschweißt

Größe	Drehmoment TKN (Nm)	Abmessungen (mm)								Technische Daten								
		L Länge	Ø A Außen- durch- messer	D1/D2 Bohrungen (H7) von-bis	H	C	E	B Stör Ø	F Schraube (ISO4762) TA (Nm)	Masse (kg)	Massen- trägheits- moment J (g m ²)	Federsteifigkeit			Versatz			max Dreh- zahl min-1
											Torsion CT 10° (Nm/rad)	radial CR (N/mm)	axial CA (N/mm)	radial ΔKr (mm)	axial ΔKa (mm)	Winkel ΔKw (°)		
18	18	63	45	10-25.4	17	5.5	19.5	47.4	M5	0.27	0.11	20	205	50	0.2	0.5	1.5	12800
		8							0.41	0.14	15	82	36	0.25	0.5	2	12800	
30	30	65	56	10-32	20	7.5	24.5	56.4	M6	0.83	0.41	38	720	50	0.15	0.6	1.5	10300
		15		0.89					0.44	28	225	28	0.25	1	2	10300		
60	60	79	66	12-35	23	10	29	66	M8	1.4	0.91	75	1150	90	0.15	0.6	1.5	8700
		40							1.7	1.00	50	340	50	0.25	1	2	8700	
80	80	91	82	14-44	28	11	33.5	82.9	M10	2.3	2	128	1200	80	0.2	0.5	1.5	6900
		84							2.4	2.1	75	400	50	0.25	0.8	2	6900	
150	150	91	82	19-44	28	11	33.5	82.9	M10	2.3	2	155	2020	145	0.2	0.5	1.5	6900
		84							2.4	2.1	105	595	85	0.25	0.8	2	6900	
200	200	101	90	22-47	31	13	38	90.8	M12	2.6	3.3	175	2500	145	0.2	0.5	1.5	6400
		125							2.7	3.5	120	460	82	0.25	0.8	2	6400	
300	300	105	110	30-60	40	13	38	110	M12	3.6	7.3	502	6300	280	0.2	0.5	1.5	6000
		145							3.7	7.5	285	1400	145	0.25	0.8	2	6000	
500	500	112	122	35-70	42	15	42	122	M12	5.1	12.4	690	7790	100	0.2	0.5	1.5	5000
		145							5.2	12.7	320	970	85	0.25	1	2	5000	

Material	Balg - Edelstahl Nabe - Edelstahl
Nabe	Bohrungstoleranz: H7
Temperaturbereich	VA -30 °C ~ 120 °C (geklebt) VAW -30 °C ~ 250 °C (lasergeschweißt)
Passfedernut	wahlweise nach DIN 6885 größtmögliche Bohrung mit # gekennzeichnet

Metallbalgkupplung

mit Innenkonus

optional
lasergeschweißt
optional komplett
in Edelstahl

optional
chem. vernickelt

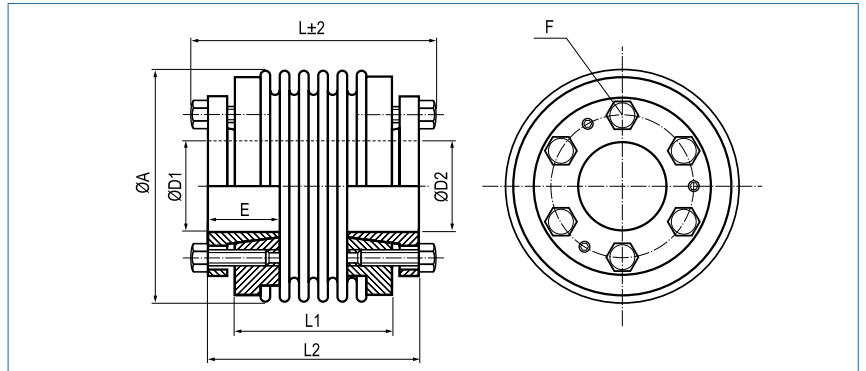

Bestellbeispiel

KB5 / 60 - 73 - 20 - 25 - (S)

Typ / Größe Länge L ØD1 (H7) ØD2 (H7) Optionen

Größe	Drehmoment TKN (Nm)	Abmessungen (mm)							Technische Daten								
		L Länge (±2)	Ø A Außen-durchmesser	D1/D2 Bohrungen (H7) von-bis	E Nabenlänge	L1	L2	F Schraube (ISO4017) TA (Nm)	Masse (kg)	Massen-trägheitsmoment J (g m²)	Federsteifigkeit			Versatz		max. Drehzahl (min-1)	
										Torsion CT 10³ (Nm/rad)	radial CR (N/mm)	axial CA (N/mm)	radial ΔKr (mm)	axial ΔKa (mm)	Winkel ΔKw (°)		
18	18	63	45	10-18	20	38	56	4xM5	0.36	0.075	20	205	50	0.2	0.5	1.5	11500
		71				46	64	4.5	0.37	0.078	15	82	36	0.25	0.5	2	
30	30	53	56	12-20	20	30	46	6xM5	0.4	0.11	38	720	50	0.15	0.6	1.5	11000
		61				38	54	4.5	0.42	0.12	28	225	25	0.25	1	2	
60	60	62	66	15-25	25	36	54	6xM6	0.77	0.32	75	1150	90	0.15	0.6	1.5	9100
		73				47	65	8.5	0.79	0.34	50	340	50	0.25	1	2	
80	80	78	82	20-35	30	50	70	6xM6	1.34	1.05	128	1200	80	0.2	0.5	1.5	7000
		90				62	82	10	1.39	1.11	75	400	50	0.25	0.8	2	
150	150	78	82	20-35	30	50	70	6xM6	1.36	1.15	155	2020	145	0.2	0.5	1.5	7000
		90				62	82	15	1.41	1.21	105	595	85	0.25	0.8	2	
200	200	78	90	20-40	30	50	70	6xM6	1.59	1.39	175	2500	145	0.2	0.5	1.5	6700
		91				63	83	15	1.66	1.49	120	460	82	0.25	1	2	
300	300	90	110	25-50	37	56	80	6xM8	3.26	4.66	502	6300	280	0.2	0.5	1.5	5200
		102				67	91	17	3.32	4.81	285	1400	145	0.25	1	2	
500	500	101	122	35-55	40	66	90	6xM8	3.78	6.11	690	7790	100	0.2	0.5	1.5	4600
		112				77	101	25	3.87	6.38	320	970	85	0.25	1	2	
800	800	170	157	50-70	60	110	150	6xM16 45	9.05	24.05	760	500	185	0.2	0.8	1.8	3700
1400	1400	170	157	50-70	60	110	150	6xM16 80	9.15	24.2	1270	700	275	0.2	0.8	1.8	3700
3000	3000	206	157	55-85	60	150	190	6xM12 85	9.43	25.7	2810	29450	1300	0.2	0.8	1.5	2800
5000	5000	206	208	60-95	80	146	186	6xM16 210	19.9	96.7	4810	4915	505	0.2	0.8	1.5	2800

Material	Balg – Edelstahl Nabe - Stahl
Nabe	Bohrungstoleranz: H7
Temperaturbereich	-30 °C ~ 120 °C Größe 800/1400: -30 °C ~ 250 °C

Metallbalgkupplung

mit Außenkonus

optional
lasergeschweißt
optional komplett
in Edelstahl

optional
chem. vernickelt

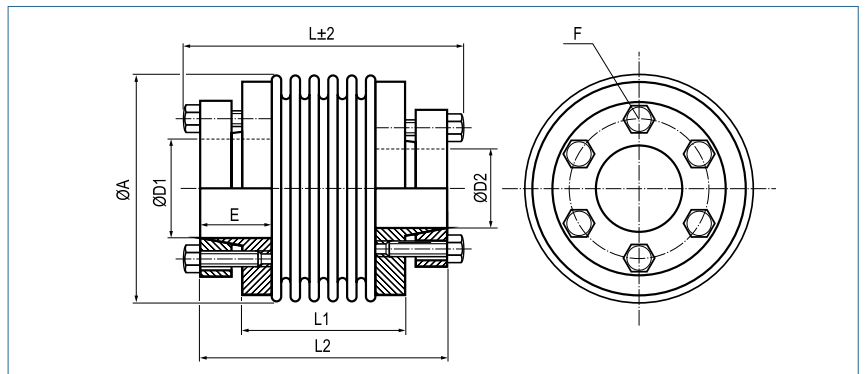

Bestellbeispiel

KB6 / 60 - 78 - 20 - 32 - (S)

Typ / Größe Länge L ØD1 (H7) ØD2 (H7) Optionen

Größe	Drehmoment TKN (Nm)	Abmessungen (mm)							Technische Daten								
		L Länge	Ø A Außen- durch- messer	D1/D2 Bohrungen (H7) von-bis	E Naben- länge	L1	L2	F Schraube (ISO4017) TA (Nm)	Masse (kg)	Massen- trägheits- moment J (g m²)	Federsteifigkeit			Versatz			max. Drehzahl (min-1)
										Torsion CT 10³ (Nm/rad)	radial CR (N/mm)	axial CA (N/mm)	radial ΔKr (mm)	axial ΔKa (mm)	Winkel ΔKw (°)		
18	18	65	45	8-15	16.5	37	58	4x M5	0.3	0.081	20	205	50	0.2	0.5	1.5	11500
		73				45	66	5.9	0.31	15	82	36	0.25	0.5	2		
30	30	60	56	12-20	18	31	53	6x M5	0.37	0.13	38	720	50	0.15	0.6	1.5	11000
		68				39	61	5.9	0.39	28	225	25	0.25	1	2		
60	60	78	66	15-32	25	36	71	6x M5	0.76	0.46	75	1150	90	0.15	0.6	1.5	9100
		89				47	82	8.7	0.79	50	340	50	0.25	1	2		
80	80	95	82	20-35	31	50	87	6x M6	1.57	1.37	128	1200	80	0.2	0.5	1.5	7000
		107				62	99	15	1.62	75	400	50	0.25	0.8	2		
150	150	95	82	20-35	31	50	87	6x M6	1.59	1.39	155	2020	145	0.2	0.5	1.5	7000
		107				62	99	15	1.64	105	595	85	0.25	0.8	2		
200	200	95	90	20-42	31	50	87	6x M6	1.6	1.64	175	2500	145	0.2	0.5	1.5	6700
		108				63	100	15	1.67	120	460	82	0.25	1	2		
300	300	108	110	25-50	34	57	98	6x M8	2.83	4.52	502	6300	280	0.2	0.5	1.5	5200
		120				68	109	25	2.89	285	1400	145	0.25	1	2		
500	500	122	122	35-55	41	59	112	6x M8	3.89	7.04	690	7790	100	0.2	0.5	1.5	4600
		134				70	123	36	3.98	320	970	85	0.25	1	2		
800	800	184	157	50-70	50	108	169	6x M12 85	8.87	24.9	760	500	185	0.2	0.8	1.8	3700
1400	1400	184	157	50-70	50	108	169	6x M12 115	8.92	25.2	1270	700	275	0.2	0.8	1.8	3700
3000	3000	220	157	55-75	60	146	204	6x M12 125	10.9	30.9	2810	2945	305	0.2	0.8	1.5	2800
5000	5000	245	208	60-90	55	146	225	6x M16 210	27.7	144.4	4810	4915	505	0.2	0.8	1.5	2800

Material	Balg – Edelstahl Nabe - Stahl
Nabe	Bohrungstoleranz: H7
Temperaturbereich	-30 °C ~ 120 °C Größe 800/1400: -30 °C ~ 250 °C

Metallbalgkupplung

axial steckbar, mit Außenkonus

optional
lasergeschweißt
optional komplett
in Edelstahl

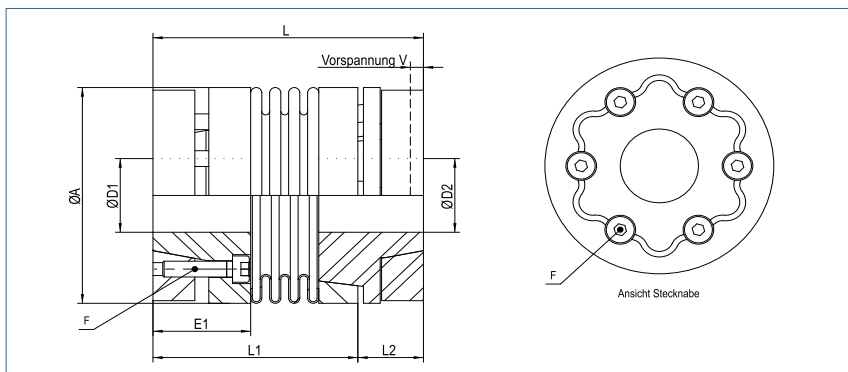

Bestellbeispiel

KB6P / 60 - 79 - 20 - 15 - D - (S)

Typ / Größe Länge L ØD1 (H7) ØD2 (H7) Steckung Optionen

Größe	Drehmoment TKN (Nm)	Abmessungen (mm)					Technische Daten									max. Drehzahl (min-1)
		L	Ø A	D1	D2	E1	F	Masse (kg)	Massenträgheitsmoment J (g m²)	Federsteifigkeit			Versatz			
		Länge	Außen-durchmesser	Bohrung (H7) von~bis	Bohrung (H7) von~bis		Schraube (ISO4762) TA (Nm)			Torsion CT 10³ (Nm/rad)	radial CR (N/mm)	axial CA (N/mm)	radial ΔKr (mm)	axial ΔKa (mm)	Winkel ΔKw (°)	
18	18	67	45	8-14	10-22	20.5	M4	0.4	0.1	20	205	50	0.2	0.5	1.5	12800
		75					4.3	0.45	0.11	15	82	36	0.25	0.5	2	
30	30	68	56	10-24	10-24	22	M5	0.48	0.16	38	720	50	0.15	0.6	1.5	10300
		76					6.5	0.5	0.18	28	225	28	0.25	1.0	2	
60	60	79	66	12-32	12-32	24	M5	0.88	0.38	75	1150	90	0.15	0.6	1.5	8700
		89					8	0.98	0.41	50	340	50	0.25	1.0	2	
150	150	97	82	15-40	15-40	35	M6	1.6	1.8	155	2020	145	0.2	0.5	1.5	6900
		108					12	1.69	1.85	105	595	85	0.25	0.8	2	
300	300	113	110	24-56	24-56	35	M8	2.28	4.05	502	6300	280	0.2	0.5	1.5	6000
		125					30	2.38	4.25	285	1400	145	0.25	0.8	2	
500	500	133	122	30-60	30-60	40	M8	3.8	7.55	690	7790	100	0.2	0.5	1.5	5000
		144					32	3.9	7.75	320	970	85	0.25	1.0	2	



Material	Balg - Edelstahl Naben - Aluminium Spannringe - Stahl
Nabe	Bohrungstoleranz: H7
Temperaturbereich	-30 °C ~ 120 °C

Größe	Abmessungen (mm)			
	L1	L2	L3	V
18	52	15	22	0.5-1.0
	60			
30	51.5	16.5	31	0.5-1.0
	59.5			
60	57	22	35	0.5-1.5
	67			
150	73	24	37.5	0.5-1.5
	84			
300	82	31	48	0.5-1.5
	93			
500	90	43	64	0.5-2.0
	101			

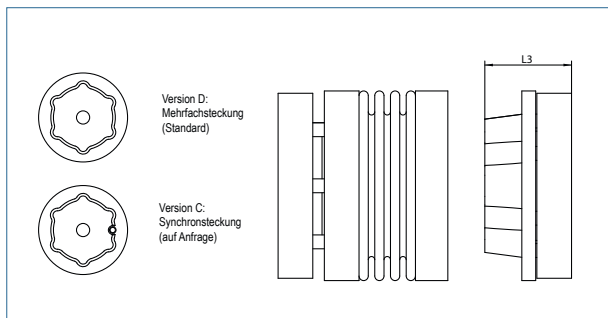

Metallbalgkupplung

Flanschausführung

optional
lasergeschweißt
optional komplett
in Edelstahl

optional
chem. vernickelt

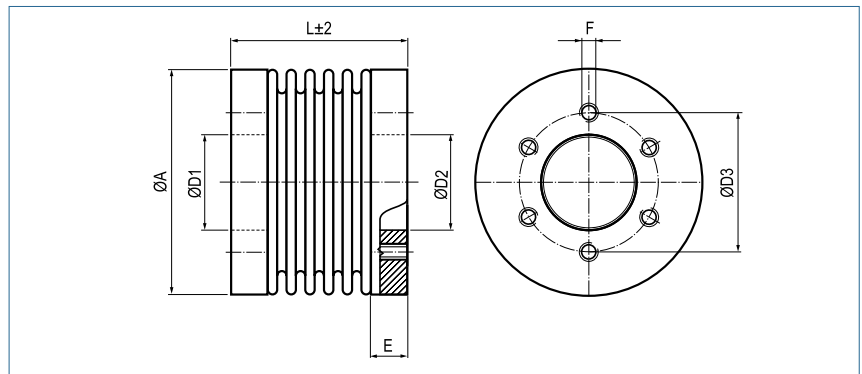

Bestellbeispiel

KB7 / 60 - 41 - 38 - (S)

Typ / Größe

Länge
L

ØD1/ØD2
(H7)

Optionen

Größe	Drehmoment TKN (Nm)	Abmessungen (mm)						Technische Daten								
		L	Ø A	Ø D1/D2	Ø D3	E	F	Masse (kg)	Massenträgheitsmoment J (g m ²)	Federsteifigkeit			Versatz			max. Drehzahl (min ⁻¹)
		Länge	Außen-durchmesser	Bohrungen (H7) von-bis			Gewinde 6x			Torsion CT 10 ³ (Nm/rad)	radial CR (N/mm)	axial CA (N/mm)	radial ΔKr (mm)	axial ΔKa (mm)	Winkel ΔKw (°)	
18	18	36	45	22	31	6	M5	0.11	0.04	20	205	50	0.2	0.5	1.5	11500
		44						0.115	0.04	15	82	36	0.25	0.5	2	
30	30	30	56	28	37	7	M5	0.16	0.09	38	720	50	0.15	0.6	1.5	11000
		38						0.17	0.09	28	225	25	0.25	1	2	
60	60	41	66	38	46	10.5	M6	0.33	0.25	75	1150	90	0.15	0.6	1.5	9100
		51						0.37	0.29	50	340	50	0.25	1	2	
80	80	50	82	50	62	13	M6	0.69	0.83	128	1200	80	0.2	0.5	1.5	7000
		62						0.75	0.92	75	400	50	0.25	1	2	
150	150	50	82	50	62	13	M6	0.69	0.83	155	2020	145	0.2	0.5	1.5	7000
		62						0.75	0.92	105	595	85	0.25	1	2	
200	200	50	90	50	62	13	M6	0.74	1.0	175	2500	145	0.2	0.5	1.5	6700
		63						0.80	1.1	120	460	82	0.25	1	2	
300	300	55	110	65	80	13	M8	1.18	2.5	502	6300	280	0.2	0.5	1.5	5200
		66						1.24	2.7	285	1400	145	0.25	1	2	
500	500	61	122	70	94	16	M8	1.95	5.0	690	7790	100	0.2	0.5	1.5	4600
		72						2.05	5.3	320	970	85	0.25	1	2	
800	800	131	157	85	110	23	M16	3.55	15	760	500	185	0.2	0.8	1.8	3700
1400	1400	131	157	85	110	23	M16	3.55	15	1270	700	275	0.2	0.8	1.8	3700
3000	3000	131	157	85	110	23	M16	3.70	16	2810	2945	305	0.2	0.8	1.5	2800
5000	5000	146	208	100	130	36.5	M16	8.22	61	4810	4915	505	0.2	0.8	1.5	2800

Material	Balg – Edelstahl Nabe - Stahl
Nabe	Bohrungstoleranz: H7
Temperaturbereich	-30 °C ~ 120 °C

Metallbalgkupplung

mit Spreiznabe

optional
lasergeschweißt
optional komplett
in Edelstahl

optional
chem. vernickelt

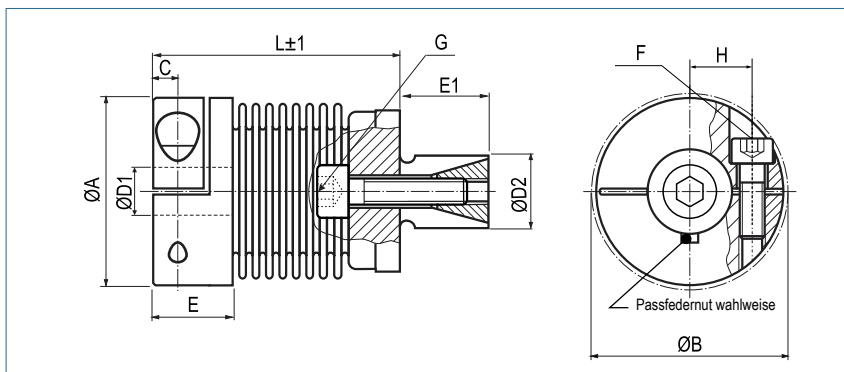

Bestellbeispiel

KB8 / 30 - 53 - 15 - 20 - S
 Typ / Größe Länge L ØD1 (H7) ØD2 (f7) Optionen

Größe	Drehmoment TKN (Nm)	Abmessungen (mm)										Technische Daten								
		L Länge	Ø A Außen-durchmesser	D1 Bohrung (H7) von-bis	D2 Spreizdorn (f7) von-bis	H	C	E	E1	B Stör Ø	F/G Schraube (ISO4762) TA (Nm)	Masse (kg)	Massen-trägheitsmoment J (g m²)	Federsteifigkeit			Versatz			max Drehzahl (min-1)
													Torsion CT 10³ (Nm/rad)	radial CR (N/mm)	axial CA (N/mm)	radial ΔKr (mm)	axial ΔKa (mm)	Winkel ΔKw (°)		
18	18	45	45	10-25.4	13-25	17	5.5	17.5	20	47.4	M5	0.14	0.04	20	205	50	0.2	0.5	1.5	12800
		52										8	0.15	0.05	15	82	35	0.25	0.5	2
30	30	53	56	10-32	14-30	20	7.5	24.5	25	56.4	M6	0.30	0.15	38	720	50	0.15	0.6	1.5	10300
		61		#30							15	0.31	0.16	28	225	28	0.25	1.0	2	10300
60	60	62	66	12-35	23-38	23	10	29	27	66	M8	0.40	0.28	75	1150	90	0.15	0.6	1.5	8700
		72									40	0.42	0.31	50	340	50	0.25	1.0	2	8700
150	150	71	82	14-44	26-42	28	11	33.5	32	82.9	M10	0.80	0.90	155	2020	145	0.2	0.5	1.5	6900
		83									84	0.85	0.95	105	595	85	0.25	0.5	2	6900
300	300	84	110	20-60	38-60	39	13	38	45	110	M12	1.62	3.28	502	6300	280	0.2	0.5	1.5	6000
		98									145	1.66	3.37	285	1400	145	0.25	0.8	2	6000
500	500	87.5	122	25-70	58-80	42	15	42	50	122	M12	3.33	5.32	690	7790	100	0.2	0.5	1.5	5000
		98.5									145	3.43	5.43	320	970	85	0.25	1	2	5000

Material Balg – Edelstahl
Klemmnabe - Aluminium
Spreiznabe -Stahl

Nabe und Hohlwelle Bohrungstoleranz: H7

Passfedernut wahlweise nach DIN 6885
größtmögliche Bohrung mit # gekennzeichnet

Temperaturbereich -30 °C ~ 120 °C

Metallbalgkupplung

axial steckbar, mit Spreiznabe

optional
lasergeschweißt
optional komplett
in Edelstahl

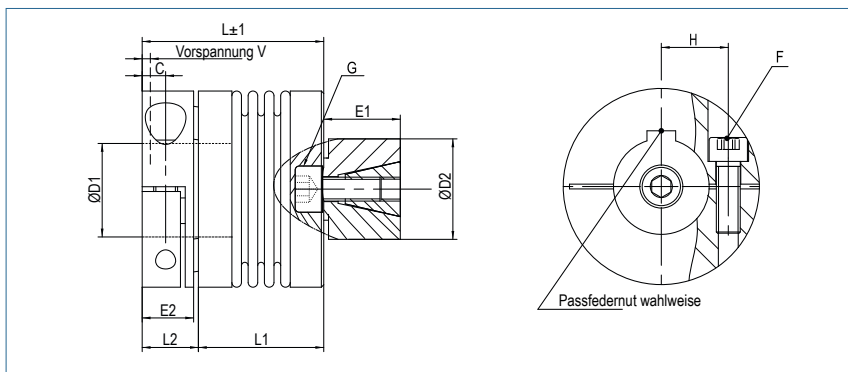

Bestellbeispiel

KB8P / 60 - 78 - 15 - 30 - D - (S)

Typ / Größe Länge L ØD1 (H7) ØD2 (f7) Steckung Optionen

Größe	Drehmoment TKN (Nm)	Abmessungen (mm)									Technische Daten									
		L	Ø A	D1	D2	H	C	E2	E1	F/G	Schraube (ISO4762) TA (Nm)	Masse (kg)	Massenträgheitsmoment J (g m²)	Federsteifigkeit			Versatz		max Drehzahl (min⁻¹)	
		Länge	Außen-durchmesser	Bohrung (H7) von-bis	Spreiz-dorn von-bis									Torsion CT 10² (Nm/rad)	radial CR (N/mm)	axial CA (N/mm)	radial ΔKr (mm)	axial ΔKa (mm)	Winkel ΔKw (°)	
18	18	52	45	10-24	13-25	17	5.5	12	20	M5	0.18	0.04	20	205	50	0.2	0.5	1.5	12800	
		60								8	0.19	0.05	15	82	36	0.25	0.5	2	12800	
30	30	59.5	56	10 32	14-30	20	7.3	17	25	M6	0.33	0.15	38	720	50	0.15	0.6	1.5	10300	
		67.5		#30						15	0.34	0.16	28	225	28	0.25	1.0	2	10300	
60	60	68	66	12-35	23-38	23	8.6	21	27	M8	0.49	0.28	75	1150	90	0.15	0.6	1.5	8700	
		78								40	0.51	0.31	50	340	50	0.25	1.0	2	8700	
150	150	75	82	14-44	26-42	28	9.8	21.5	32	M10	0.87	0.90	155	2020	145	0.2	0.5	1.5	6900	
		87								84	0.92	0.95	105	595	85	0.25	0.8	2	6900	
300	300	93	110	20-60	38-60	39	10.8	27	45	M12	1.87	3.28	502	6300	280	0.2	0.5	1.5	6000	
		107								145	1.91	3.37	285	1400	145	0.25	0.8	2	6000	
500	500	112	122	25-70	58-80	42	15	42	50	M12	3.83	6.52	690	7790	100	0.2	0.5	1.5	5000	
		123								145	3.93	6.63	320	970	85	0.25	1	2	5000	



Material	Balg - Edelstahl Klemmnabe - Aluminium Spreiznabe - Stahl
Nabe	Bohrungstoleranz: H7
Temperaturbereich	-30 °C ~ 120 °C
Passfedernut	wahlweise nach DIN 6885 größtmögliche Bohrung mit # gekennzeichnet

Größe	Abmessungen (mm)			
	L1	L2	L3	V
18	33.5	14	22	0.5-1.0
	40.5			
30	40.5	19	31	0.5-1.0
	48.5			
60	45	23	35	0.5-1.5
	55			
150	51.5	23.5	37.5	0.5-1.5
	63.5			
300	64	29	47	0.5-1.5
	78			
500	68	44	66	0.5-2.0
	79			

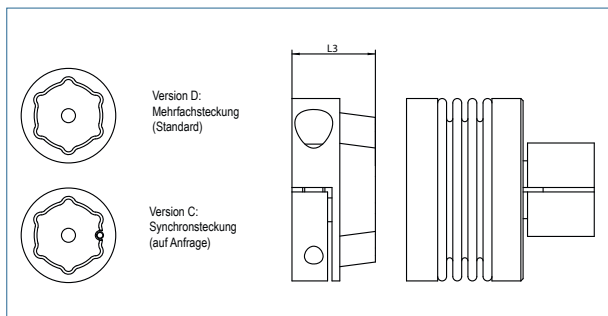

Elastomerkupplungen

KBE1 | 5 ~ 55

Elastomerkupplung
Nabe mit Stiftschraube



S. 34

KBE2 | 5 ~ 19

Elastomerkupplung
mit Klemmnabe



S. 35

KBE2 | 24 ~ 55

Elastomerkupplung
mit Klemmnabe



S. 36

KBE2C | 7 ~ 48

Elastomerkupplung
Kompaktversion



S. 37

KBE2H | 14 ~ 55

Elastomerkupplung
Halbschalenausführung



S. 38

KBE2HC | 14 ~ 48

Elastomerkupplung
Halbschalenausführung



S. 39

KBE2D | 7 ~ 48

Elastomerkupplung
doppelkardanisch mit Klemmnabe



S. 40

KBE3 | 14 ~ 55

Elastomerkupplung
mit Außenkonus



S. 41

KBE3C | 14 ~ 55

Elastomerkupplung
Kompaktversion mit Außenkonus



S. 42

KBE4 | 14 ~ 48

Elastomerkupplung
mit Spreiznabe



S. 43

Elastomerkupplung

mit Stiftschrauben

optional komplett
in Edelstahl

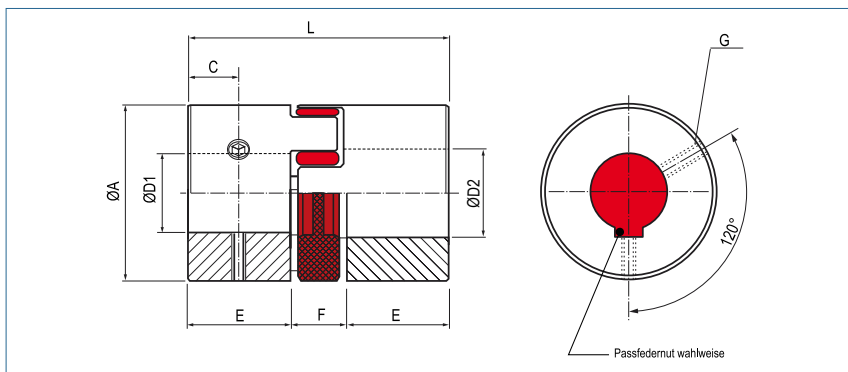

Bestellbeispiel

KBE1 - 14 - 10 - 12 - 98Sh

Typ Größe ØD1 (H7) ØD2 (H1) Shorehärte

Größe	Abmessungen (mm)						Technische Daten			Drehmoment (Nm)				
	Ø A Außendurchmesser	L Länge	Ø D1-D2 Bohrungen (H7) von-bis	E	F	C	F Schraube (ISO4029) TA (Nm)	Maximal drehzahl rpm. (1/min)	Masse (pro Kupplung) (g)	Massenträgheitsmoment (pro Kupplung) J (g m²)	64 ShoreD (grün)	98 ShoreA (rot)	92 ShoreA (gelb)	80 ShoreA (blau)
5	10	15	2 - 6	5	5	2.5	1 x M3 0.5	47500	2.62	0.0000216	x	x	0.5	x
7	14	22	4 - 7	7	8	3.5	2 x M3 1.3	34000	6.5	0.00018	2.4	2	1.2	0.7
9	20	30	6 - 9	10	10	5	2 x M3 1.3	24000	22	0.00105	6	5	3	1.8
12	25	34	6 - 12	11	12	5	1 x M4 3	19500	33	0.00309	12	9	5	3
14	30	35	6 - 16	11	13	5	1 x M4 3	16000	45	0.006	16	12.5	7.5	4
19	40	66	10 - 24	25	16	10	1 x M5 6	12000	187	0.040	26	21	12	6
24	55	78	16 - 28	30	18	10	1 x M5 6	8500	420	0.171	75	60	35	17
28	65	90	20 - 38	35	20	15	1 x M6 11	7200	577	0.368	200	160	95	46
38	80	114	20 - 45	45	24	15	1 x M8 25	6000	1200	1125	405	325	190	x
42	95	126	20 - 55	50	26	20	1 x M8 25	4800	1850	16103	560	450	265	x
48	105	140	20 - 60	56	28	20	1 x M8 25	4300	2562	4124	655	525	310	x
55	120	160	20 - 65	65	30	26	1 x M10 84	4000	3280	7.663	825	685	410	x

Material Nabe - Aluminium
 Zahnkranz - Polyurethan

Nabe Bohrungstoleranz: H7

Passfedernut wahlweise nach DIN 6885

Weitere Shorehärten und technische Daten finden Sie auf Seite 44 und 45.
 Alle Baureihen auch mit spielbehafteten Zahnkränzen erhältlich (siehe Seite 45).

Elastomerkupplung

mit Klemmnabe

optional komplett
in Edelstahl

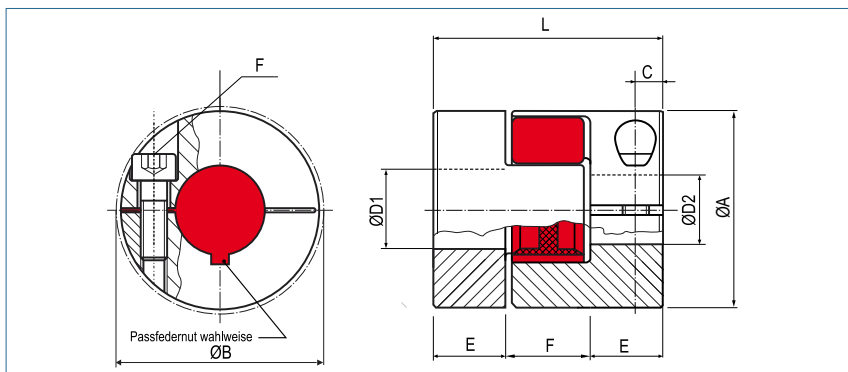

Bestellbeispiel

KBE2 - 14 - 10 - 12 - 98Sh

Typ Größe ØD1 (H7) ØD2 (H7) Shorehärte

Größe	Abmessungen (mm)								Technische Daten			Drehmoment (Nm)			
	ØA Außen- durch- messer	L Länge	Ø D1-D2 Bohrungen (H7) von-bis	E	F	C	B	F Schraube (ISO4762) TA (Nm)	Maximal- drehzahl rpm. (1/min)	Masse (pro Kupplung) (g)	Massenträg- heitsmoment (pro Kupplung) J (g m ²)	64 ShoreD (grün)	98 ShoreA (rot)	92 Shore A (gelb)	80 ShoreA (blau)
5	10	15	2 - 5	5	5	2.5	11.4	M1.6 0.25	38000	2.52	0.000036	x	x	0.5	x
7	14	22	4 - 7	7	8	3.5	15	M2 0.43	27000	7	0.000195	2.4	2	1.2	0.7
9	20	30	4 - 11	10	10	5	23.4	M2.5 0.85	19000	18.52	0.00107	6	5	3	1.8
12	25	34	4 - 12	11	12	5	27.2	M3 2	16000	33	0.00304	12	9	5	3
14	30	35	4 - 16	11	13	5	32.2	M3 2	13000	59	0.00381	16	12.5	7.5	4
19	40	66	10 - 22/24*	25	16	12	47	M6 15	10000	183	0.0404	26	21	12	6

Größe	Reibschlußmoment (Nm) bei Bohrungsdurchmesser (mm)																					
	2	3	4	5	6	7	8	9	10	11	12	13	14	15	16	17	18	19	20	21	22	
5	06	0.6	0.7	0.8																		
7			1.3	1.4	1.5	1.6																
9			2.3	2.4	2.5	2.7	2.8	2.9	3.0	3.2												
12			6.3	6.6	6.9	7.2	7.4	7.7	8.0	8.3	8.6											
14			7.7	8.0	8.3	8.6	8.9	9.2	9.4	9.7	10	10.3	10.6	10.9	11.2							
19									44	45	47	48	49	50	51	52	54	55	56	57	58	



Material Nabe - Aluminium
 Zahnkranz - Polyurethan

Nabe Bohrungstoleranz: H7

Passfedernut wahlweise nach DIN 6885

* Für Bohrungen > 22H7 bis 24H7 werden die Naben mit 2xM4 gefertigt.

Weitere Shorehärten und technische Daten finden Sie auf Seite 44 und 45.

Alle Baureihen auch mit spielbehafteten Zahnkränzen erhältlich (siehe Seite 44).

Elastomerkupplung

mit Klemmnabe

optional komplett in Edelstahl

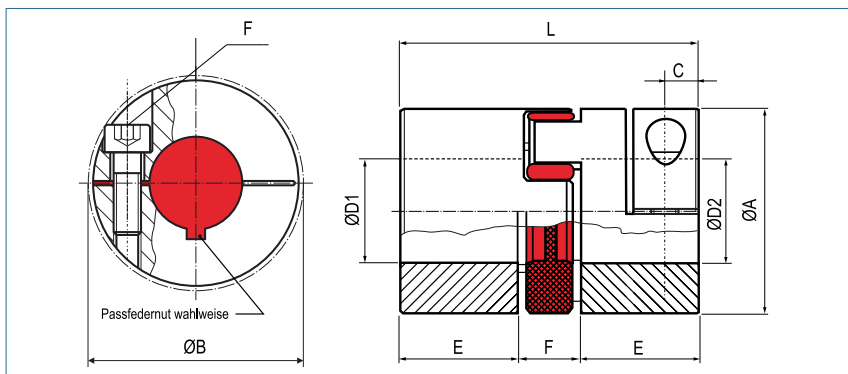

Bestellbeispiel

KBE2 - 38 - 20 - 40 - 98Sh

Typ Größe ØD1 (H7) ØD2 (H7) Shorehärte

Größe	Abmessungen (mm)							Technische Daten			Drehoment (Nm)				
	ØA Außen- durch- messer	L Länge	Ø D1-D2 Bohrungen (H7) von-bis	E	F	C	B Stör Ø	F Schraube (ISO4762) TA (Nm)	Maximal- drehzahl rpm. (1/min)	Masse (pro Kupplung) (g)	Massenträg- heitsmoment J (pro Kupplung) (g m ²)	64 ShoreD (grün)	98 ShoreA (rot)	92 ShoreA (gelb)	80 ShoreA (blau)
24	55	78	15 - 32	30	18	12	56.4	M6 15	7000	394	0.175	75	60	35	17
28	65	90	19 - 37	35	20	15	72.6	M8 40	6000	624	0.377	200	160	95	46
38	80	114	20 - 48	45	24	20	83.3	M8 40	5000	1230	1.139	405	325	190	x
42	95	126	25 - 50	50	26	20	95	M10 84	4000	1960	2.505	560	450	265	x
48	105	140	25 - 57	56	28	22	105	M12 145	3750	2690	4.175	655	525	310	x
55	120	160	25 - 74	65	30	20	122.8	M12 145	3500	3333	7.545	825	685	410	x

Größe	Reibschlußmoment (Nm) bei Bohrungsdurchmesser (mm)																												
	15	16	19	20	22	24	25	28	30	32	35	38	39	40	42	44	45	46	48	50	52	54	56	58	60	62	65	70	74
24	64	65	69	70	72	74	76	79	81	84																			
28			114	116	119	123	124	130	133	137	142																		
38				135	138	142	144	149	152	156	161	166	168	169	173	176	178												
42							294	304	310	317	327	337	340	343	350	357	360	363	370	376									
48							476	491	500	510	524	539	544	548	558	568	572	577	587	596	606	616							
55							529	544	553	563	577	592	596	601	611	620	625	630	640	649	659	669	678	688	697	707	722	746	765

+

Material Nabe - Aluminium
 Zahnkranz - Polyurethan

Nabe Bohrungstoleranz: H7

Passfedernut wahlweise nach DIN 6885

Weitere Shorehärten und technische Daten finden Sie auf Seite 44 und 45.

Alle Baureihen auch mit spielbehafeten Zahnkränzen erhältlich (siehe Seite 45).

Elastomerkupplung kompakt

optional komplett in Edelstahl

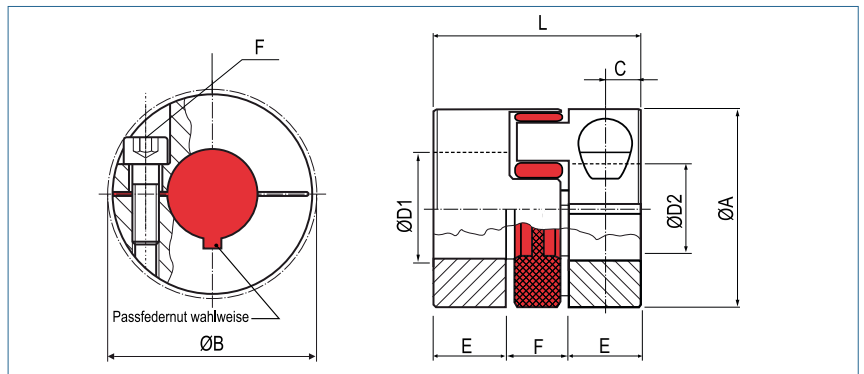

Bestellbeispiel

KBE2C - 38 - 20 - 40 - 98Sh

Typ Größe ØD1 (H7) ØD2 (H7) Shorehärte

Größe	Abmessungen (mm)								Technische Daten			Drehmoment (Nm)			
	Ø A Außen- durch- messer	L Länge	Ø D1-D2 Bohrungen (H7) von-bis	E	F	C	B	G Schraube (ISO4762) TA (Nm)	Maximal- drehzahl rpm. (1/min)	Masse (pro Kupplung) (g)	Massenträg- heitsmoment J (pro Kupplung) (g m²)	64 ShoreD (grün)	98 ShoreA (rot)	92 ShoreA (gelb)	80 ShoreA (blau)
7	14	18	3 - 7	5	8	2.5	16.6	M2 0.43	27000	6	0.00018	2.4	2	1.2	0.7
9	20	24	4 - 11	7	10	3.5	21.3	M2.5 0.85	19000	15	0.00085	6	5	3	1.8
12	25	26	4 - 12	7	12	3.5	27.2	M3 2	16000	23	0.00220	12	9	5	3
14	30	32	4 - 16	9.5	13	5	30.5	M4 4.5	13000	45	0.0166	16	12.5	7.5	4
19	40	50	8 - 21	17	16	8.5	45.7	M6 15	10000	139	0.0311	26	21	12	6
24	55	58	10 - 32	20	18	10	56.4	M6 15	7000	271	0.119	75	60	35	17
28	65	62	14 - 37	21	20	11	72.6	M8 40	6000	429	0.254	200	160	95	46
38	80	86	15 - 48	31	24	15	83.3	M10 84	5000	888	0.828	405	325	190	x
42	95	94	20 - 50	34	26	17.5	97.6	M12 145	4000	1425	1.866	560	450	265	x
48	105	110	20 - 57	47.5	28	23	105	M12 145	3750	2019	3.221	655	525	310	x

Reibschlußmoment (Nm) bei Bohrungsdurchmesser (mm)

Größe	3	4	6	8	10	12	14	15	16	18	19	20	24	25	28	30	32	35	38	40	42	45	48	50	55	
7	1.2	1.3	1.5																							
9		2.3	2.5	2.8	3.0																					
12		6.6	6.9	7.4	8.0	8.6																				
14			14	14.7	15.7	16.7	17.7	18.3	18.8																	
19				42	44	47	49	50	51	54	55	56														
24					58	61	63	64	65	67	69	70	74	76	79	81	84									
28							105	107	109	112	114	116	123	124	130	133	137	142	147							
38								241	244	251	254	258	271	274	284	291	297	307	317	324	330	340	350			
42												433	452	457	471	481	491	505	519	529	539	553	568	577		
48												452	471	476	491	500	510	524	539	548	558	572	587	596	620	

+ **Material** Nabe - Aluminium
 Zahnkranz - Polyurethan
Nabe Bohrungstoleranz: H7
Passfedernut wahlweise nach DIN 6885
 Weitere Shorehärten und technische Daten finden Sie auf Seite 44 und 45.
 Alle Baureihen auch mit spielbehafteten Zahnkränzen erhältlich (siehe Seite 45).

Elastomerkupplung

Halbschalenausführung

optional komplett in Edelstahl

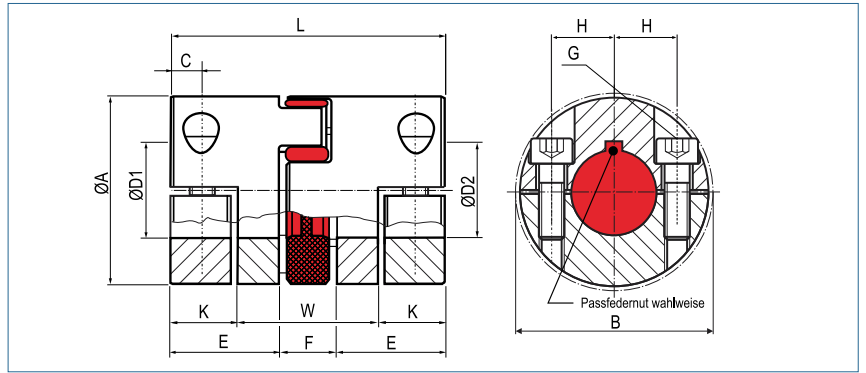
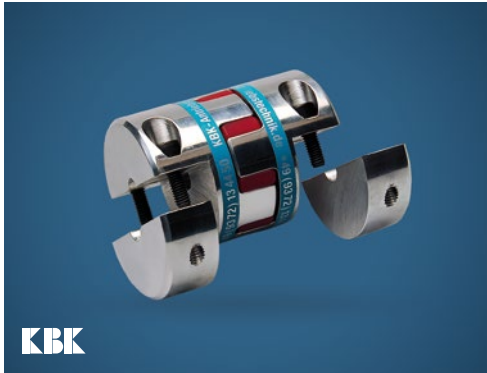

Bestellbeispiel

KBE2H - 19 - 10 - 12 - 98Sh

Typ Größe ØD1 (H7) ØD2 (H7) Shorehärte

Größe	Abmessungen (mm)										Technische Daten				Drehmoment (Nm)			
	Ø A	L	Ø D1/D2	E	W	F	C	B	H	K	G Schraube (ISO4762) TA (Nm)	Maximaldrehzahl rpm. (1/min)	Masse (pro Kupplung) (g)	Massenträgheitsmoment (pro Kupplung) J (g m²)	64 ShoreD (grün)	98 ShoreA (rot)	92 ShoreA (gelb)	80 ShoreA (blau)
9	20	30	4 - 11	10	14	10	5	23.5	7	8	M2.5 0.85	19000	20	0.00121	6	5	3	1.8
12	25	34	4 - 16	11	18	12	5	27.2	8.25	8	M3 2	16000	36	0.00354	12	9	5	3
14	30	35	4 - 16	11	19	13	5.0	35	10.5	8	M4 5	13000	50	0,007	16	12.5	7.5	4
19	40	66	8 - 21	25	27	16	8.0	46	14.5	19.5	M6 15	10000	182	0,042	26	21	12	6
24	55	78	10 - 32	30	34	18	10.5	57.5	20	22.0	M6 15	7000	391	0,171	75	60	35	17
28	65	90	14 - 37	35	40	20	11.5	73	25	25.0	M8 40	6000	643	0,402	200	160	95	46
38	80	114	18 - 48	45	48	24	15.5	83.5	30	33.0	M8 40	5000	1167	1,096	405	325	190	x
42	95	126	22 - 50	50	53	26	18.0	93.5	32	36.5	M10 84	4000	1943	2,522	560	450	265	x
48	105	140	22 - 57	56	61	28	18.5	105	36	39.5	M12 145	3750	2592	4,076	655	525	310	x
55	120	160	25 - 74	65	70	30	26	122.8	45	45	M12 145	3500	3260	7.349	825	685	410	x

Größe	Reibschlußmoment (Nm) bei Bohrungsdurchmesser (mm)																												
	4	6	8	10	14	15	16	18	20	22	24	25	28	30	32	35	38	40	42	45	48	50	55	58	60	65	70	74	
9	3	4	6	7																									
12	6	9	12	15	21	22	24																						
14	11	16	21	26	37	39	42																						
19			47	59	83	89	95	107	119																				
24				59	83	89	95	107	119	130	142	148	166	178	190														
28					123	132	141	159	176	194	211	220	247	264	282	308													
38							159	176	194	211	220	247	264	282	308	335	352	370	396	423									
42										370	404	420	471	505	538	589	639	673	706	757	807	841							
48											539	588	612	686	735	784	857	931	980	1029	1102	1176	1225	1347					
55												612	686	735	784	857	931	980	1029	1102	1176	1225	1347	1421	1470	1592	1715	1813	

+ **Material** Nabe - Aluminium
Zahnkranz - Polyurethan

Nabe Bohrungstoleranz: H7

Passfedernut wahlweise nach DIN 6885

Weitere Shorehärten und technische Daten finden Sie auf Seite 44 und 45.
Alle Baureihen auch mit spielbehafteten Zahnkränzen erhältlich (siehe Seite 45).

Elastomerkupplung kompakt

Halbschalenausführung

optional komplett in Edelstahl

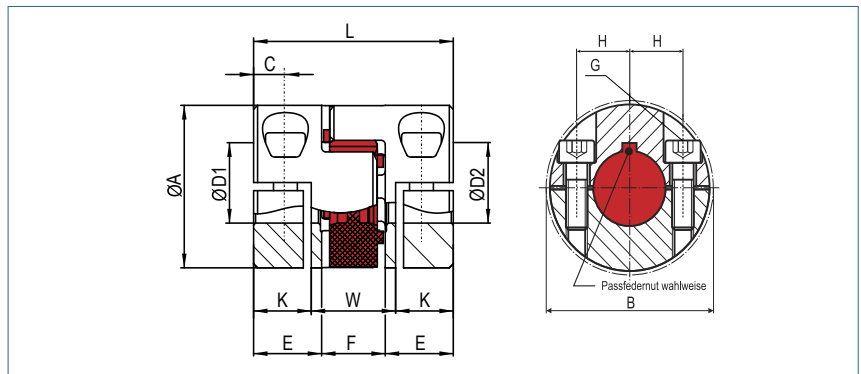

Bestellbeispiel **KBE2HC - 19 - 10 - 12 - 98Sh**

Typ Größe ØD1 (H7) ØD2 (H7) Shorehärte

Größe	Abmessungen (mm)											Technische Daten			Drehmoment (Nm)			
	Ø A	L	Ø D1/D2	E	W	F	K	C	B	H	G	Maximaldrehzahl rpm. (1/min)	Masse (pro Kupplung) (g)	Massenträgheitsmoment (pro Kupplung) J (g m ²)	64 ShoreD (grün)	98 ShoreA (rot)	92 ShoreA (gelb)	80 ShoreA (blau)
14	30	32	4 - 16	9.5	16.4	13	7.8	4,5	35	10.5	M4 4.5	13000	47	0.006	16	12.5	7.5	4
19	40	50	8 - 21	17	21	16	14.5	8.0	46	14.5	M6 15	10000	79	0.019	26	21	12	6
24	55	58	10 - 32	20	26	18	16	8	57.5	20	M6 15	7000	280	0.121	75	60	35	17
28	65	62	14 - 37	21	28	20	17	9	73	25	M8 40	6000	421	0.266	200	160	95	46
38	80	86	18 - 48	31	38	24	24	12	83.5	30	M8 40	5000	840	0.790	405	325	190	x
42	95	94	22 - 50	34.5	44	25	25	12,5	93.5	32	M10 84	4000	1416	1.832	560	450	265	x
48	105	110	22 - 57	41	50	28	30	14	105	36	M12 145	3750	1956	3.101	655	525	310	x

Größe	Reibschlußmoment (Nm) bei Bohrungsdurchmesser (mm)																										
	4	6	8	10	11	14	15	16	18	19	20	22	24	25	28	30	32	35	38	40	42	45	46	48	50	55	
14	10.3	15.5	20.7	25.8	28.4	36.1	38.7	41.3																			
19			47	59	65	83	89	95	107	113	119																
24				59	65	83	89	95	107	113	119	130	142	148	166	178	190										
28						123	132	141	159	167	176	194	211	220	247	264	282	308	335								
38									159	167	176	194	211	220	247	264	282	308	335	352	370	396	405	423			
42												370	404	420	471	505	538	589	639	673	706	757	774	807	841		
48												539	588	612	686	735	784	857	931	980	1029	1102	1127	1176	1225	1347	

Material Nabe - Aluminium
Zahnkranz - Polyurethan

Nabe Bohrungstoleranz: H7

Passfedernut wahlweise nach DIN 6885

Weitere Shorehärten und technische Daten finden Sie auf Seite 44 und 45.

Alle Baureihen auch mit spielbehafteten Zahnkränzen erhältlich (siehe Seite 45).

Elastomerkupplung

doppelkardanisch mit Klemmnabe

optional komplett in Edelstahl

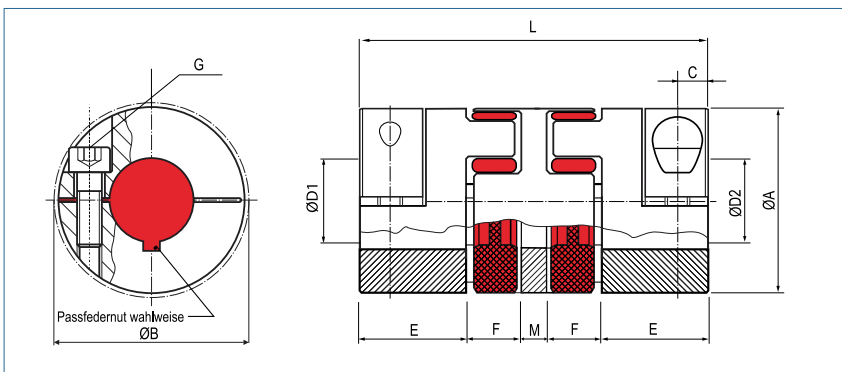

Bestellbeispiel

KBE2D - 14 - 10 - 12 - 98Sh

Typ Größe ØD1 (H7) ØD2 (H7) Shorehärte

Größe	Abmessungen (mm)									Technische Daten/Nabe			Drehmoment (Nm)			
	ØA	L	Ø D1-D2	E	F	C	B	G	M	Maximaldrehzahl rpm. (1/min)	Masse (pro Kupplung) (g)	Massenträgheitsmoment J (pro Kupplung) (g m ²)	64 ShoreD (grün)	98 ShoreA (rot)	92 ShoreA (gelb)	80 ShoreA (blau)
7	14	34	4 - 7	7	8	3.5	15	M2 0.43	4	27000	5	0.002	2.4	2	1.2	0.7
9	20	45	4 - 11	10	10	5	23.4	M2.5 0.85	5	19000	32	0.002	6	5	3	1.8
12	25	52	4 - 12	11	12	8	27.2	M3 2	6	16000	51	0.00459	12	9	5	3
14	30	56	4 - 16	11	13	5	32.2	M3 2	8	13000	77	0.010	16	12.5	7.5	4
19	40	92	10 - 22/24*	25	16	12	45.7	M6 15	10	10000	232	0.056	26	21	12	6
24	55	112	15 - 32	30	18	14	56.6	M6 15	16	7000	534	0.188	75	60	35	17
28	65	128	19 - 37	35	20	15	70.2	M8 40	18	6000	844	0.507	200	160	95	46
38	80	158	20 - 48	45	24	20	82.5	M8 40	20	5000	1580	1.489	405	325	190	x
42	95	174	25 - 50	50.5	26	18	95	M10 84	21	4000	2270	3.144	560	450	265	x
48	105	192	25 - 62	55	28	20	107.2	M12 145	26.5	3000	2970	5.117	655	525	310	x

Reibschlußmoment (Nm) bei Bohrungsdurchmesser (mm)

Größe	4	5	6	7	8	9	10	11	12	14	15	16	19	20	22	24	25	28	30	32	35	38	40	42	45
7	1.3	1.4	1.5	1.6																					
9	2.3	2.4	2.5	2.7	2.8	2.9	3.0	3.2																	
12	6.3	6.6	6.9	7.2	7.4	7.7	8.0	8.3	8.6																
14	7.7	8.0	8.3	8.6	8.9	9.2	9.4	9.7	10	10.6	10.9	11.2													
19							44	45	47	49	50	51	55	56	58										
24											64	65	69	70	72	74	76	79	81	84					
28													114	116	119	123	124	130	133	137	142				
38														135	138	142	144	149	152	156	161	166	169	173	178
42																	294	304	310	317	327	337	343	350	360
48																	476	497	500	510	524	539	548	558	572



Material Nabe - Aluminium
Nabe Zahnkranz - Polyurethan
 Bohrungstoleranz: H7
Passfedernut wahlweise nach DIN 6885

* Für Bohrungen > 22H7 bis 24H7 werden die Naben mit 2xM4 gefertigt.

Weitere Shorehärten und technische Daten finden Sie auf Seite 44 und 45. Alle Baureihen auch mit spielbehafteten Zahnkränzen erhältlich (siehe S. 45).

Elastomerkupplung

mit Außenkonus

optional komplett in Edelstahl

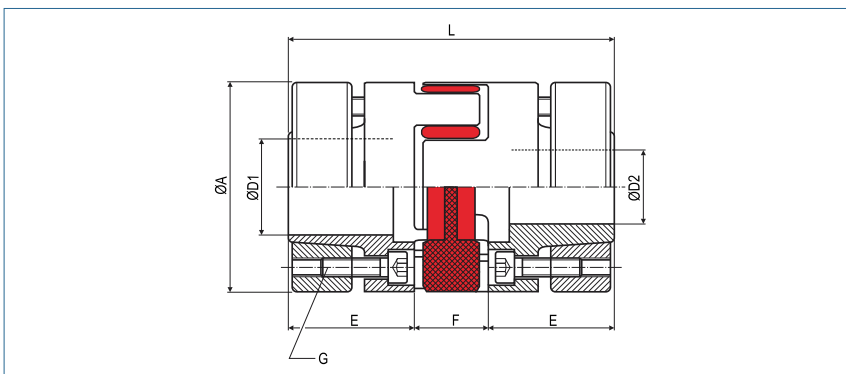

Bestellbeispiel

KBE3 - 48 - 40 - 35 - 98Sh

Typ Größe ØD1 (H7) ØD2 (H7) Shorehärte

Größe	Abmessungen (mm)						Technische Daten			Drehmoment (Nm)			
	Ø A Außen- durchmesser	L Länge	Ø D1-D2 Bohrungen (H7) von-bis	E	F	G Schraube (ISO4762) TA (Nm)	Maximal- drehzahl rpm. (1/min)	Masse (pro Kupplung) (g)	Massen- trägheits- moment (pro Kupplung) J (g m ²)	64 ShoreD (grün)	98 ShoreA (rot)	92 ShoreA (gelb)	80 ShoreA (blau)
14	30	50	6 - 14	18.5	13	M3 1.34	25000	105	0.014	16	12.5	7.5	4
19	40	66	10 - 20	25	16	M4 2.9	19000	277	0.066	26	21	12	6
24	55	78	15 - 28	30	18	M5 6	14000	612	0.282	75	60	35	17
28	65	90	19 - 38	35	20	M5 6	12000	937	0.650	200	160	95	46
38	80	114	20 - 45	45	24	M6 10	10000	1961	2.005	405	325	190	x
42	95	126	28 - 50	50	26	M8 35	8000	3069	4.322	560	450	265	x
48	105	140	35 - 60	56	28	M8 35	7000	3855	6.851	655	525	310	x
55	120	160	40 - 70	65	30	M10 84	5000	4145	10.252	825	685	410	x

Größe	Reibschlußmoment (Nm) bei Bohrungsdurchmesser (mm)																								
	6	10	11	14	15	16	19	20	24	25	28	30	32	35	38	40	42	45	48	50	55	60	65	70	
14	8.6	13.8	14.7	22.7																					
19		41	45	62	68	67	83	90																	
24					74	72	90	97	112	120	143														
28							189	188	237	250	280	307	310	353	389										
38								269	337	356	398	436	424	501	533	572	585	644							
42											445	506	470	566	581	647	630	728	836	858					
48														955	999	1092	1091	1230	1381	1334	1540				
55																	1262	1325	1422	1464	1582	1630	1975	1994	2352

+ **Material** Nabe - Aluminium
 Spannung - Stahl
 Zahnkranz - Polyurethan

Nabe Bohrungstoleranz: H7

Weitere Shorehärten und technische Daten finden Sie auf Seite 44 und 45.
 Alle Baureihen auch mit spielbehafteten Zahnkränzen erhältlich (siehe Seite 45).

Elastomerkupplung kompakt

mit Außenkonus

optional komplett in Edelstahl

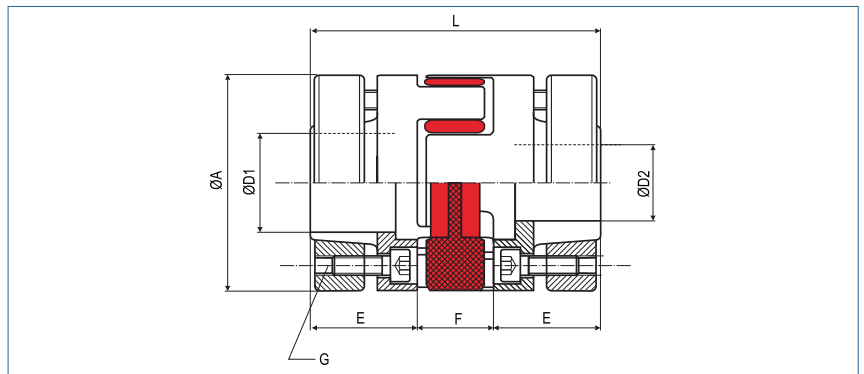

Bestellbeispiel

KBE3C - 48 - 40 - 35 - 98Sh

Typ Größe ØD1 (H7) ØD2 (H7) Shorehärte

Größe	Abmessungen (mm)						Technische Daten			Drehmoment (Nm)			
	Ø A Außen- durch- messer	L Länge	Ø D1-D2 Bohrungen (H7) von-bis	E	F	G Schraube (ISO4762) TA (Nm)	Maximal- drehzahl rpm. (1/min)	Masse (pro Kupplung) (g)	Massen- trägheits- moment (pro Kupplung) J (g m²)	64 ShoreD (grün)	98 ShoreA (rot)	92 ShoreA (gelb)	80 ShoreA (blau)
14	30	42	6 - 14	14.5	13	M3 1.34	25000	91	0.012	16	12.5	7.5	4
19	40	56	10 - 20	20	16	M4 3	19000	252	0.063	26	21	12	6
24	55	64	14 - 28	23	18	M5 6	14000	492	0.236	75	60	35	17
28	65	76	19 - 38	28	20	M5 6	12000	776	0.535	200	160	95	46
38	80	96	20 - 45	36	24	M6 10	10000	1639	1.686	405	325	190	x
42	95	103	28 - 50	38.5	26	M8 35	8000	2612	3.621	560	450	265	x
48	105	110	30 - 55	41	28	M8 35	7000	3105	5.465	655	525	310	x
55	120	136	40 - 70	53	30	M10 84	5000	4145	10.252	825	685	410	x

Größe	Reibschlußmoment (Nm) bei Bohrungsdurchmesser (mm)																							
	6	10	11	14	15	16	19	20	24	25	28	30	32	35	38	40	42	45	48	50	55	60	65	70
14	5.4	7.5	11.3	24.7																				
19		17	20	41	49	52	56	64																
24				47	57	67	98	110	127	139	175													
28							121	133	201	219	248	285	253	307	329									
38								203	304	331	394	452	453	543	550	609	669	634						
42											444	508	535	638	692	763	754	858	964	976				
48											572	638	762	842	929	943	1074	1208	1136	1336				
55															1073	1126	1209	1244	1345	1386	1679	1695	1998	

+ **Material** Nabe - Aluminium
 Spannung - Stahl
 Zahnkranz - Polyurethan

Nabe Bohrungstoleranz: H7

Weitere Shorehärten und technische Daten finden Sie auf Seite 44 und 45.

Alle Baureihen auch mit spielbehafteten Zahnkränzen erhältlich (siehe Seite 45).

Elastomerkupplung

mit Spreiznabe

optional komplett in Edelstahl

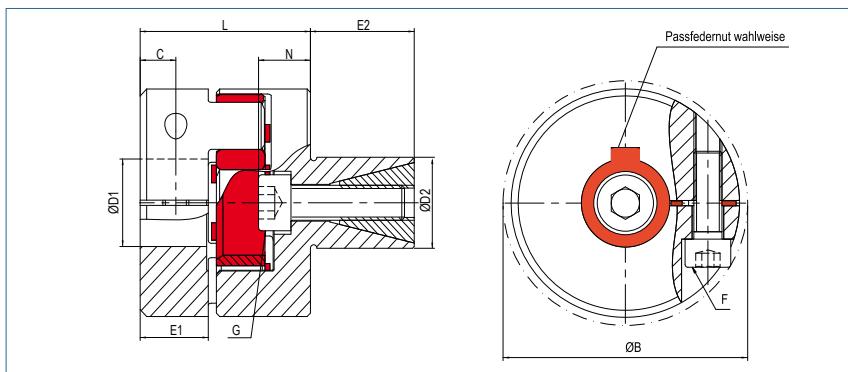

Bestellbeispiel

KBE4 - 38 - 40 - 35 - 98Sh

Typ Größe ØD1 (H7) ØD2 (h7) Shorehärte

Größe	Abmessungen (mm)											Technische Daten			Drehmoment (Nm)			
	ØA	L	Ø D1	Ø D2	E1	E2	N	C	B	F	G	Maximaldrehzahl upm. (1/min)	Masse (pro Kupplung) (g)	Massenträgheitsmoment (pro Kupplung) J (g m²)	64 ShoreD (grün)	98 ShoreA (rot)	92 ShoreA (gelb)	80 ShoreA (blau)
14	30	28	4-16	13 - 25	11	20	7	5	32.2	M3 2	M5 9	20000	98	0.010	16	12.5	7.5	4
19	40	40	10-22/24*	14 - 30	17	25	10	9	45.7	M6 15	M6 15	19000	240	0.042	26	21	12	6
24	55	46	12 - 32	23 - 36	20	27	11	10	56.4	M6 15	M8 40	14000	463	0.158	75	60	35	17
28	65	51	19 - 37	26 - 42	21	32	16	11	72.6	M8 40	M10 84	11500	799	0.375	200	160	95	46
38	80	68	20 - 48	38 - 60	31	45	20	15	83.3	M8 40	M12 145	9500	1754	1.213	405	325	190	x
42	95	92.5	25 - 50	42 - 80	51	55	21	18	95	M10 84	M16 310	6031	3966	4.180	560	450	265	x
48	105	102	25 - 62	42 - 90	55	60	24.5	20	108	M12 145	M16 310	5457	5392	7030	655	525	310	x

Größe	Reibschlußmoment (Nm) bei Bohrungsdurchmesser (mm)																							
	4	6	8	9	10	11	12	14	15	16	18	19	20	24	25	28	30	32	35	38	40	42	45	
14	7.7	8.3	8.9	9.2	9.4	9.7	10	10.6	10.9	11.2														
19					44	45	47	49	50	51	54	55	56											
24							61	63	64	65	67	69	70	74	76	79	81	84						
28												114	116	123	124	130	133	137	142					
38													135	142	144	149	152	156	161	166	169	173	178	
42															294	304	310	317	327	337	343	350	360	
48															476	491	500	510	524	539	548	558	572	

Material Nabe - Aluminium
 Spreiznabe - Stahl
 Zahnkranz - Polyurethan

Nabe Bohrungstoleranz: H7

Passfedernut wahlweise nach DIN 6885

* Für Bohrungen > 22H7 bis 24H7 werden die Naben mit 2xM4 gefertigt.

Weitere Shorehärten und technische Daten finden Sie auf Seite 44 und 45.

Alle Baureihen auch mit spielbehafteten Zahnkränzen erhältlich (siehe Seite 45).

spielfreie Zahnkränze zu Elastomerkupplungen

Typ KBE Serie

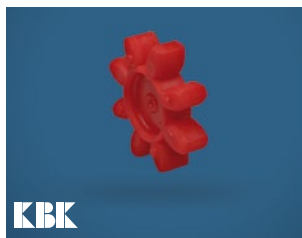

80 ShoreA

Dauer temperatur: -50 bis +80
max. Temp. kurzzeitig: -60 bis +120

92 ShoreA

Dauer temperatur: -30 bis +90
max. Temp. kurzzeitig: -50 bis +120

98 ShoreA

Dauer temperatur: -30 bis +90
max. Temp. kurzzeitig: -40 bis +120

64 ShoreD

Dauer temperatur: -20 bis +110
max. Temp. kurzzeitig: -30 bis +120

Bestellbeispiel

ZK19 - 98Sh

Typ / Größe

Shorehärte

Größe	Zahnkranz	Drehmoment [Nm]		Drehfedersteife statisch [Nm/rad]	Drehfedersteife dynamisch [Nm/rad]	Federsteifigkeit radial [N/mm]	Versatz			max. Durchgangsbohrung [mm]
		TK Nenn	TK max				axial [mm]	radial [mm]	angular [Grad]	
5	92 ShA	0.5	0.6	5.16	16	154	+0.4 / -0.2	0.06	1.0°	3
7	80 ShA	0.7	1.4	8.6	26	114	+0.6 / -0.3	0.15	1.1°	3
	92 ShA	1.2	2.4	14.3	43	219	+0.6 / -0.3	0.10	1.0°	
	98 ShA	2	4	22.9	69	421	+0.6 / -0.3	0.10	1.0°	
	64 ShD	2.4	4.8	34.3	103	630	+0.6 / -0.3	0.04	0.8°	
9	80 ShA	1.8	3.6	17.2	52	125	+0.8 / -0.4	0.2	1.1°	7
	92 ShA	3	6	31.5	95	262	+0.8 / -0.4	0.15	1.0°	
	98 ShA	5	10	51.6	155	518	+0.8 / -0.4	0.1	0.9°	
	64 ShD	6	12	74.6	224	739	+0.8 / -0.4	0.05	0.8°	
12	80 ShA	3	6	84.3	252	274	+0.9 / -0.4	0.20	1.1°	8
	92 ShA	5	10	160.4	482	470	+0.9 / -0.4	0.14	1.0°	
	98 ShA	9	18	240.7	718	846	+0.9 / -0.4	0.08	0.9°	
	64 ShD	12	24	327.9	982	1198	+0.9 / -0.4	0.05	0.8°	
14	80 ShA	4	8	60.2	180	153	+1.0 / -0.5	0.21	1.1°	10
	92 ShA	7.5	15	114.6	344	336	+1.0 / -0.5	0.15	1.0°	
	98 ShA	12.5	25	171.9	513	654	+1.0 / -0.5	0.09	0.9°	
	64 ShD	16	32	234.2	702	856	+1.0 / -0.5	0.06	0.8°	
19	80 ShA	6	12	618	1065	582	+1.2 / -0.5	0.15	1.1°	18
	92 ShA	12	24	1090	1815	1120	+1.2 / -0.5	0.10	1.0°	
	98 ShA	21	42	1512	2540	2010	+1.2 / -0.5	0.06	0.9°	
	64 ShD	26	52	2560	3810	2930	+1.2 / -0.5	0.04	0.8°	
24	80 ShA	17	34	860	1390	840	+1.4 / -0.5	0.2	1.0°	27
	92 ShA	35	70	2300	5130	1900	+1.4 / -0.5	0.15	1.0°	
	98 ShA	60	120	3700	8130	2940	+1.4 / -0.5	0.11	0.9°	
	64 ShD	75	150	5030	11500	4200	+1.4 / -0.5	0.08	0.8°	
28	80 ShA	46	92	1370	2350	990	+1.5 / -0.7	0.2	1.3°	30
	92 ShA	95	190	4080	6745	1780	+1.5 / -0.7	0.15	1.0°	
	98 ShA	160	320	6410	9920	3200	+1.5 / -0.7	0.11	0.9°	
	64 ShD	200	400	10260	20177	4348	+1.5 / -0.7	0.08	0.8°	
38	92 ShA	190	380	6525	12000	2350	+1.8 / -0.7	0.17	1.0°	38
	98 ShA	325	650	11800	21850	4400	+1.8 / -0.7	0.12	0.9°	
	64 ShD	405	810	26300	40335	6474	+1.8 / -0.7	0.09	0.8°	
42	92 ShA	265	530	10870	20500	4100	+2.0 / -1.0	0.19	1.0°	46
	98 ShA	450	900	21594	37692	5940	+2.0 / -1.0	0.14	0.9°	
	64 ShD	560	1120	36860	71400	7590	+2.0 / -1.0	0.10	0.8°	
48	92 ShA	310	620	12968	22800	4500	+2.1 / -1.0	0.23	1.0°	51
	98 ShA	525	1050	25759	49400	6820	+2.1 / -1.0	0.16	0.9°	
	64 ShD	655	1310	57630	102800	9000	+2.1 / -1.0	0.11	0.8°	
55	92 ShA	410	820	15482	21375	2980	+2.2 / -1.0	0.24	1.0°	58
	98 ShA	685	1370	42117	61550	6686	+2.2 / -1.0	0.17	0.9°	
	64 ShD	825	1650	105730	130200	9248	+2.2 / -1.0	0.12	0.8°	

spielbehaftete Zahnkränze zu Elastomerkupplungen

Typ KBES Serie



92 ShoreA

Dauer temperatur: -30 bis +90
max. Temp. kurzzeitig: -50 bis +120

98 ShoreA

Dauer temperatur: -30 bis +90
max. Temp. kurzzeitig: -40 bis +120

Bestellbeispiel

ZKES24 - 92Sh

Typ / Größe

Shorehärte

Größe	Zahnkranz	Drehmoment [Nm]		Drehfedersteife statisch [Nm/rad]	Drehfedersteife dynamisch [Nm/rad]	Federsteifigkeit radial [N/mm]	Versatz			Durchgangsbohrung [mm]
		TK Nenn	TK max				axial [mm]	radial [mm]	angular [Grad]	
5	92 ShA	0.5	0.6	5.16	16	154	+0.4 / -0.2	0.06	1.0°	3
7	92 ShA	1.2	2.4	14.3	43	219	+0.6 / -0.3	0.10	1.0°	3
	98 ShA	2	4	22.9	69	421	+0.6 / -0.3	0.10	1.0°	
9	92 ShA	3	6	31.5	95	262	+0.8 / -0.4	0.15	1.0°	7
	98 ShA	5	10	51.6	155	518	+0.8 / -0.4	0.1	0.9°	
12	92 ShA	5	10	160.4	482	470	+0.9 / -0.4	0.14	1.0°	8
	98 ShA	9	18	240.7	718	846	+0.9 / -0.4	0.08	0.9°	
14	92 ShA	7.5	15	114.6	344	336	+1.0 / -0.5	0.15	1.0°	10
	98 ShA	12.5	25	171.9	513	654	+1.0 / -0.5	0.09	0.9°	
19	92 ShA	12	24	1090	1815	1120	+1.2 / -0.5	0.10	1.0°	18
	98 ShA	21	42	1512	2540	2010	+1.2 / -0.5	0.06	0.9°	
24	92 ShA	35	70	2300	5130	1900	+1.4 / -0.5	0.15	1.0°	27
	98 ShA	60	120	3700	8130	2940	+1.4 / -0.5	0.11	0.9°	
28	92 ShA	95	190	4080	6745	1780	+1.5 / -0.7	0.15	1.0°	30
	98 ShA	160	320	6410	9920	3200	+1.5 / -0.7	0.11	0.9°	
38	92 ShA	190	380	6525	12000	2350	+1.8 / -0.7	0.17	1.0°	38
	98 ShA	325	650	11800	21850	4400	+1.8 / -0.7	0.12	0.9°	
42	92 ShA	265	530	10870	20500	4100	+2.0 / -1.0	0.19	1.0°	46
	98 ShA	450	900	21594	37692	5940	+2.0 / -1.0	0.14	0.9°	
48	92 ShA	310	620	12968	22800	4500	+2.1 / -1.0	0.23	1.0°	51
	98 ShA	525	1050	25759	49400	6820	+2.1 / -1.0	0.16	0.9°	
55	92 ShA	410	820	15482	21375	2980	+2.2 / -1.0	0.24	1.0°	58
	98 ShA	685	1370	42117	61550	6686	+2.2 / -1.0	0.17	0.9°	

Bestellbeispiele für Elastomerkupplungen mit spielbehafteten Zahnkränzen

KBES1	-	28	-	N24	-	N30	-	92 Sh
statt KBE1		Größe		Bohrung1 mit Nut		Bohrung2 mit Nut		Shorehärte
KBES2	-	42	-	30	-	45	-	98 Sh
statt KBE2		Größe		Bohrung1		Bohrung2		Shorehärte
KBES2D	-	19	-	10	-	22	-	98 Sh
statt KBE2D		Größe		Bohrung1		Bohrung2		Shorehärte

Gelenkkupplungen

GK | 18 ~ 100

Gelenkkupplung
Linearkupplung mit Gewinde



S. 47

GK-T | 18 ~ 100

Gelenkkupplung
mit Klemmnabe



S. 48

GK-TH | 27 ~ 100

Gelenkkupplung
in Halbschalenausführung



S. 49

Gelenkkupplung

Linearkupplung mit Gewinde

optional komplett in Edelstahl

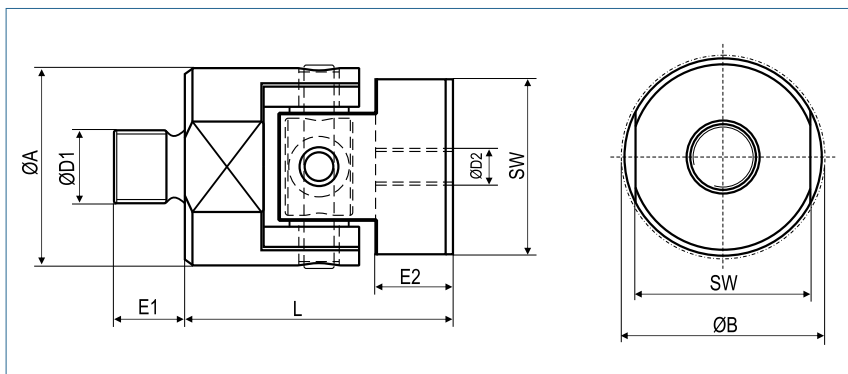

Bestellbeispiel

GK / 27 - M5 - M6

Typ / Größe

Gewinde Zapfen Ø D1

Gewinde Bohrung Ø D2

Größe	Axialkraft F_{KA} (N)	Abmessungen (mm)					Technische Daten					
		L Länge	Ø A Außen-durch-messer	SW Schlüssel-weite	E2 max. Einschraub-tiefe	B Stör Ø	Masse (kg)	Massen-trägheitsmoment J (kg mm ²)	Federsteifigkeit axial CA (N/mm)	Versatz		max Drehzahl min ⁻¹
18	200	24	18	16	5.5	19	0.013	0.52	8500	1	6	10000
27	800	36	27	24	10.5	30	0.046	4.25	14800	1	6	7500
35	1000	37	35	32	11	39	0.082	12.37	19000	1.5	6	6000
56	4000	60	56	50	15	61	0.31	121	33000	2	6	3750
75	7500	75	74.5	65	25	80	0.87	594	42800	2	6	2850
100	13000	78	100	90	27	106	1.83	2194	62000	2.5	6	2100

Größe	Nabenausführung	Gewindegröße (übertragbare Axialkraft in N)													
		M3	M4	M5	M6	M8	M10	M12	M16	M20	M24	M30	M36	M42	M48
18	Zapfen D1	510	670	857	1017	1380									
	Zapfenlänge E1	5	6	8	8	10									
	Gewinde D2	634	1105	1788	2531	4631									
27	Zapfen D1		670	857	1017	1380	1740								
	Zapfenlänge E1		6	8	8	10	12								
	Gewinde D2	634	1105	1788	2531	4631	7313								
35	Zapfen D1					1380	1740	1970	2710						
	Zapfenlänge E1					10	12	15	20						
	Gewinde D2			1788	2531	4631	7313	10603	9800						
56	Zapfen D1							1970	2710	3386	4064	5142			
	Zapfenlänge E1							15	20	25	30	36			
	Gewinde D2					4631	7313	10603	9800	15400	22140	35344			
75	Zapfen D1									3386	4064	5142	6218		
	Zapfenlänge E1									25	30	36	40		
	Gewinde D2						7313	10603	9800	15400	22140	35344	51390		
100	Zapfen D1											5142	6218	7296	8374
	Zapfenlänge E1											36	40	48	55
	Gewinde D2							10603	9800	15400	22140	35344	51390	70484	92625

Material
 Innenring - Aluminium
 Nabe - Aluminium
 Stifte - Stahl

Temperaturbereich -100 °C ~ 250 °C

Gelenkkupplung

mit Klemmnabe

optional komplett in Edelstahl

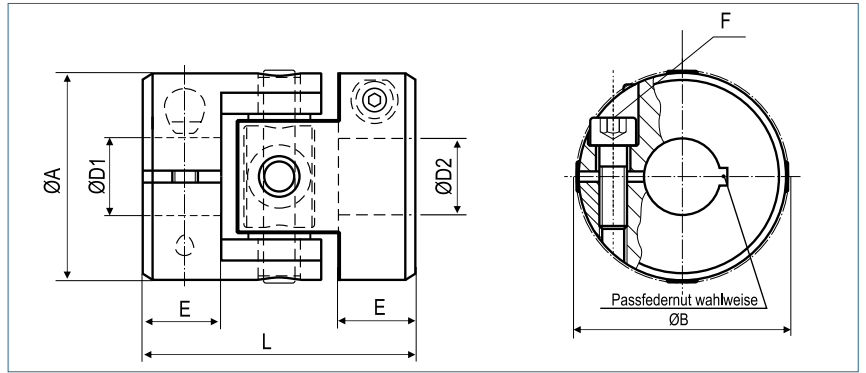

Bestellbeispiel

GK-T / 27 - 6 - 10

Typ / Größe

ØD1 (H7)

ØD2 (H1)

Größe	Drehmoment T_{KN} (Nm)	Drehmoment T_{kmax} (Nm)	Abmessungen (mm)						Technische Daten					
			L	Ø A	D1/D2	B	E	F	Masse (kg)	Massenträgheitsmoment J (kg mm ²)	Torsionssteifigkeit CT (Nm/rad)	Versatz		max Drehzahl min ⁻¹
			Länge	Außendurchmesser	Bohrungen (H7)	Stör Ø	Nabengänge	Schraube (ISO 4762) TA (Nm)				radial ΔKr (mm)	Winkel ΔKw (°)	
18	2	3	24	18	3-10	19	5.5	M2 0.54	0.011	0.526	458	0.6	6	10000
27	5	10	36	27	4-14	30	10.5	M3 1.9	0.040	4.30	802	1	6	7500
35	10	18	37	35	5-20	39	11	M4 4.6	0.069	12.19	1701	1.5	6	6000
56	35	100	53	56	8-32	61	15	M6 15.7	0.278	124	20630	2	6	3750
75	100	250	83	74.5	10-41	80	25	M8 38	0.76	609	51575	2	6	2850
100	250	580	97	100	20-55	106	27	M12 130	1.60	2246	85943	2.5	6	2100

Größe	Reibschlußmoment (Nm) bei Bohrungsdurchmesser (mm)																								
	3	4	6	8	10	14	15	16	18	20	22	24	25	28	30	32	35	38	40	42	45	48	50	55	
18	1.9	2	2.3	2.5	2.8																				
27		6.9	7.4	8.0	8.6																				
35			16.4	17.4	18.5	20.5	20.9	21.6	22.6	23.6															
56				57	59	64	65	66	69	72	73	76	78	80	83	85									
75					143	151	153	156	160	164	166	173	175	181	186	190	196	199	207						
100										475	485	495	504	515	525	530	550	560	575	580	600	615	625	650	

+ **Material** Innenring - Aluminium
Nabe - Aluminium
Stifte - Stahl

Temperaturbereich -100 °C ~ 250 °C

Gelenkkupplung

in Halbschalenausführung

optional komplett
in Edelstahl

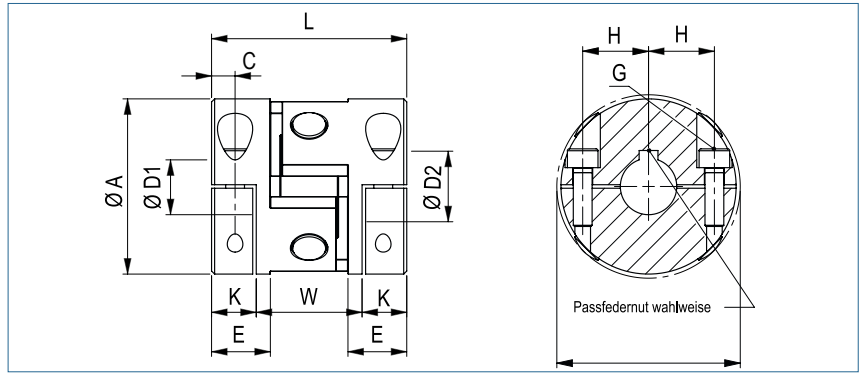

Bestellbeispiel GK-TH / 27 - 6 - 10

Typ / Größe ØD1 (H7) ØD2 (H1)

Größe	Drehmoment T_{KN} (Nm)	Drehmoment T_{kmax} (Nm)	Abmessungen (mm)									Technische Daten						
			L	Ø A	D1/D2	B	C	K	W	H	E	F	Masse (kg)	Massenträgheitsmoment J (kg mm ²)	Torsionssteifigkeit CT (Nm/rad)	Versatz		max Drehzahl min-1
			Länge	Außendurchmesser	Bohrungen (H7)	Stör Ø					Nabenhöhe	Schraube (ISO 4762) TA (Nm)				radial ΔKr (mm)	Winkel ΔKw (°)	
27	5	10	36	27	4-14	30	3.5	7.5	21	10	10.5	M3 1.9	0.040	4.30	802	1	6	7500
35	10	18	37	35	5-20	39	4.5	8.5	20	13	11	M4 4.6	0.069	12.19	1701	1.5	6	6000
56	35	100	53	56	8-32	61	6.5	12	29	20	15	M6 15.7	0.278	124	20630	2	6	3750
75	100	250	83	74.5	10-41	80	10	19	45	28	25	M8 38	0.76	609	51575	2	6	2850
100	250	580	97	100	20-55	106	12	21.5	54	37.5	27	M12 130	1.60	2246	85943	2.5	6	2100

Reibschlußmoment (Nm) bei Bohrungsdurchmesser (mm)																							
Größe	4	6	8	10	14	15	16	18	20	22	24	25	28	30	32	35	38	40	42	45	48	50	55
27	5.8	8.7	11.5	14.4	20.2																		
35		15.5	20.7	25.8	36.1	38.7	41.3	46.5	51.6														
56			47.4	59.3	83	88.9	94.8	106.7	118.5	130.4	142.2	148.1	165.9	177.8	189.6								
75				109	152	163	174	195	217	239	261	271	304	326	347	380	413	434					
100									503	553	603	628	704	754	804	879	955	1005	1055	1131	1206	1256	1382

Material
 Innenring - Aluminium
 Nabe - Aluminium
 Stifte - Stahl

Temperaturbereich -100 °C ~ 250 °C

Distanzkupplungen

DRE | 9 ~ 48

Distanzkupplung in Halbschalenausführung mit Elastomersternen



S. 51

DRB | 4.5 ~ 500

Distanzkupplung in Halbschalenausführung mit Bälgen

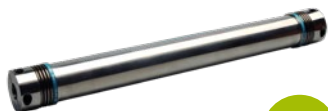

S. 52

Distanzkupplung

in Halbschalenausführung und mit Elastomern

optional
lasergeschweißt
optional komplett
in Edelstahl

optional
mit Carbonrohr

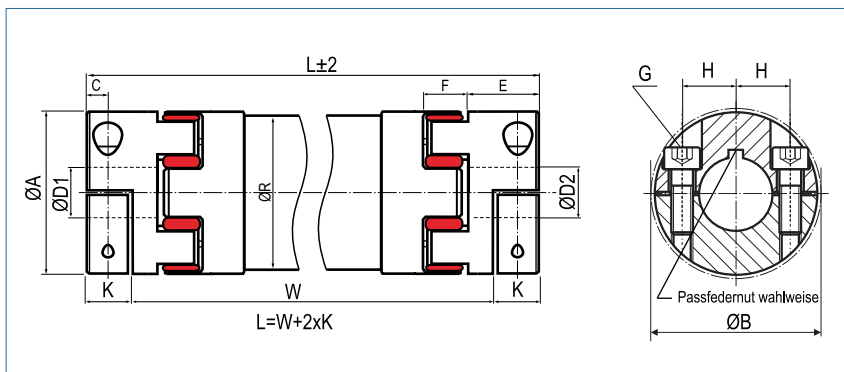

Bestellbeispiel

DRE / 19 - 2000 - 10 - 16 - 98Sh

Typ / Größe Länge ØD1 (H7) ØD2 (H7) Shorehärte

Größe	Abmessungen (mm)											Technische Daten		Drehmoment (Nm)				
	Ø D1/D2		Ø A	E	K	F	L		R	B	C	H	G ISO4762	CT/m (Nm/rad)	64 ShoreD (grün)	98 ShoreA (rot)	92 ShoreA (gelb)	80 ShoreA (blau)
	Bohrungen (H7)	Außen- durch- messer					min	max										
9	4	11	20	10	8	10	90	3000	20	23.5	5	7	M2.5 0.85	300	6	5	3	1.8
12	4	16	25	11	8	12	95	3000	25	27.2	5	8.25	M3 2	550	12	9	5	3
14	4	16	30	11	8	13	102	3000	30	34	5	10.5	M4 5	500	16	12.5	7.5	4
19	8	21	40	25	19.5	16	133	3000	35	46	8.0	14.5	M6 15	1770	26	21	12	6
24	10	32	55	30	22.0	18	157	3000	50	57.5	10.5	20	M6 15	6400	75	60	35	17
28	14	37	65	35	25.0	20	181	3000	60	73	11.5	25	M8 40	11400	200	160	95	46
38	18	48	80	45	33.0	24	229	3000	75	83.5	15.5	30	M8 40	23000	405	325	190	x
42	22	50	95	50	36.5	26	253	3000	100	93.5	18.0	32	M10 84	194000	560	450	265	x
48	22	57	105	56	39.5	28	281	3000	100	105	18.5	36	M12 145	194000	655	525	310	x

Größe	Reibschlußmoment (Nm) bei Bohrungsdurchmesser (mm)																								
	4	6	8	10	14	15	16	18	19	20	22	24	25	28	30	32	35	38	40	42	45	46	48	50	55
9	2.6	3.9	5.2	6.5																					
12	5.8	8.7	11.7	14.6	20.4	21.8	23.3																		
14	10.3	15.5	20.7	25.8	36.1	38.7	41.3																		
19			47	59	83	89	95	107	113	119															
24				59	83	89	95	107	113	119	130	142	148	166	178	190									
28					123	132	141	159	167	176	194	211	220	247	264	282	308	335							
38								159	167	176	194	211	220	247	264	282	308	335	352	370	396				
42											370	404	420	471	505	538	589	639	673	706	757	774	807	841	
48											539	588	612	686	735	784	857	931	980	1029	1102	1127	1176	1225	1347

Material Nabe: Aluminium
Zahnkranz: Polyurethan
Zwischenrohr: Aluminium

Nabe Bohrungstoleranz: H7

Passfedernut wahlweise nach DIN 6885

Längere Ausführungen bis 6 m auf Anfrage!
Informationen zu zulässigen Achsversätzen und maximalen Drehzahlen finden Sie in unseren Betriebs – und Montageanleitungen.
Weitere Shorehärten und technische Daten finden Sie auf Seite 44 und 45.
Alle Baureihen auch mit spielbehafteten Zahnkränzen erhältlich (siehe S. 45).

Distanzkupplung

in Halbschalenausführung mit Bälgen

optional
lasergeschweißt
optional komplett
in Edelstahl

optional
mit Carbonrohr

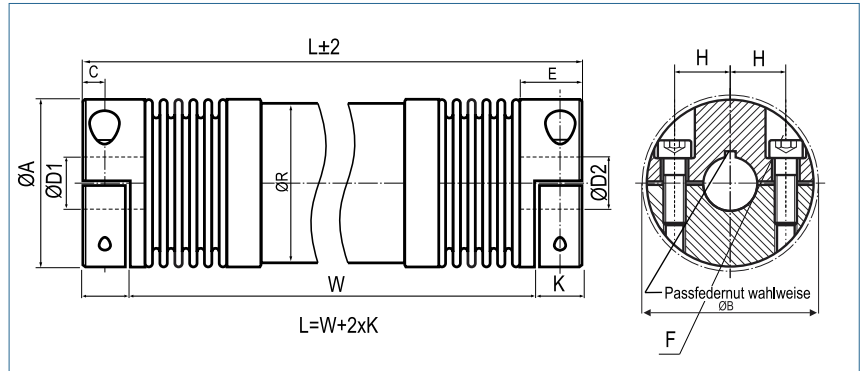

Bestellbeispiel

DRB / 60 - 2000 - 15 - 20 - (S)

Typ / Größe

Länge

ØD1
(H7)

ØD2
(H7)

Optionen

Größe	Drehmoment TKN (Nm)	Abmessungen (mm)										Technische Daten		
		L		Ø A	D1/D2	H	C	E	K	F	R	B	Federsteifigkeit	
		min	max	Außendurchmesser	Bohrungen (H7)					Schraube (ISO4762) TA (Nm)	Rohr Ø	Stör Ø	Torsion Bälge $C_T \cdot 10^3$ (Nm/rad)	Torsion Rohr $C_T \cdot 10^3$ (Nm/rad)
4.5	4.5	68	3000	32.5	6-16	12	5	14	8.5	M4 3,5	30	34	3.2	0.5
10	10	82	3000	40.5	6-25	15.5	5	14	9	M4 4,5	35	41.5	4.1	1.8
18	18	108	3000	45	10-25.4	17	5.5	19.5	13	M5 8	35	47.4	10	1.8
30	30	111	3500	56	10-30	20	7.5	27	17	M6 15	50	56.4	19	6.5
60	60	135	4000	66	12-35	23	9.5	31	21	M8 40	60	66	37.5	11.5
150	150	154	4000	82	14-44	28	11	36	23.5	M10 84	75	82.9	77.5	23
200	200	169	4000	90	16-48	31	12.5	41	27	M12 125	90	90.8	87.5	73
300	300	179	4000	110	20-60	40	13	43	28	M12 145	100	110	251	194
500	500	215	4000	122	25-65	42	15	51	35.5	M12 145	100	122	345	194



Material Balg - Edelstahl
Naben - Aluminium
Zwischenrohr - Aluminium

Passfedernut wahlweise nach DIN 6885

Temperaturbereich -30 °C ~ 120°C

Längere Ausführungen bis 6 m auf Anfrage!

Eine Balgbruchsicherung ist automatisch integriert.

Informationen zu zulässigen Achsversätzen und maximalen Drehzahlen finden Sie in unseren Betriebs – und Montageanleitungen.

Schlitzkupplungen

KBFK | 16 ~ 80

Schlitzkupplung
mit Klemmnaben



S. 54

KBFH | 30 ~ 80

Schlitzkupplung
in Halbschalenausführung



S. 55

Schlitzkupplung

mit Klemmnaben

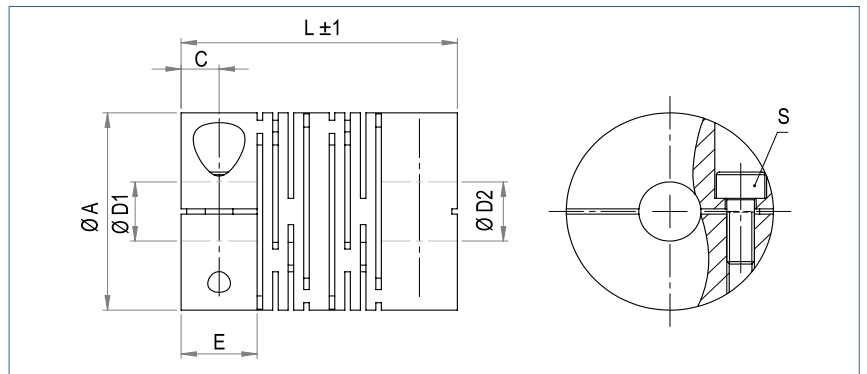

Bestellbeispiel

KBFK / 30 - 8 - 12 - AL

Typ / Größe ØD1 (H7) ØD2 (H7) Material

Größe	Drehmoment TKN (Nm) AL	Drehmoment TKN (Nm) VA	Abmessungen (mm)					S	Masse (kg) AL	Masse (kg) VA	Massenträgheitsmoment J AL (g m²)	Massenträgheitsmoment J VA (g m²)	Technische Daten		Versatz			max Drehzahl min-1
			L	Ø A	D1/D2	E	C						Torsion CT 10³ (Nm/rad) AL	Torsion CT 10³ (Nm/rad) VA	radial ΔKr (mm)	axial ΔKa (mm)	Winkel ΔKw (°)	
16	3	6	23	16	3-6	7	3.5	M2.5x6 1	10	28	0.00028	0.00080	0.076	0.513	0.15	0.5	2.0	10000
18	3	6	16.6	18	3-6	5.5	2.75	M2.5x8 1	5	18	0.00045	0.00123	0.103	0.752	0.15	0.5	2.0	10000
20	5	12	28	20	3-8	8	4	M2.5x8 1	15	45	0.00105	0.00288	0.407	1.189	0.1	1	1.0	9500
22	3	6	20	22	3-10	5.5	2.75	M2.5x8 1	12	40	0.00115	0.00490	0.690	1.372	0.15	1	1.0	9500
25	7	16	28	25	6-12	8	4	M3x10 1.5	25	75	0.00239	0.00648	0.733	1.558	0.1	1	1.0	8000
30	10	25	40	30	6-14	11	5.5	M4x10 3.4	50	160	0.00680	0.01860	0.868	2.530	0.1	0.85	1.0	6000
40	19	36	48	40	6-19	11	5.5	M5x14 7	115	340	0.02790	0.07580	3.767	11.008	0.15	0.85	1.0	5000
50	35	73	65	50	10-26	19	9.5	M6x16 14	250	650	0.08970	0.24600	7.196	20.995	0.15	0.7	1.5	5000
60	70	110	80	60	10-30	25	12.5	M8x18 27	500	1150	0.25370	0.69400	12.750	37.165	0.15	0.7	1.5	4500
70	130	190	95	70	15-35	25	12.5	M8x25 27	750	1753	0.50660	1.38000	66.768	196.024	0.1	0.33	1.0	4000
80	180	240	100	80	20-40	25	12.5	M8x30 27	1040	2330	0.96240	2.62000	78.189	229.524	0.1	0.33	1.0	3500

+ **Material** Kupplung: Aluminium oder Edelstahl

Nabe Bohrungstoleranz: H7

Passfedernut wahlweise nach DIN 6885

Sondermaterialien auf Anfrage.

Schlitzkupplung

in Halbschalenausführung

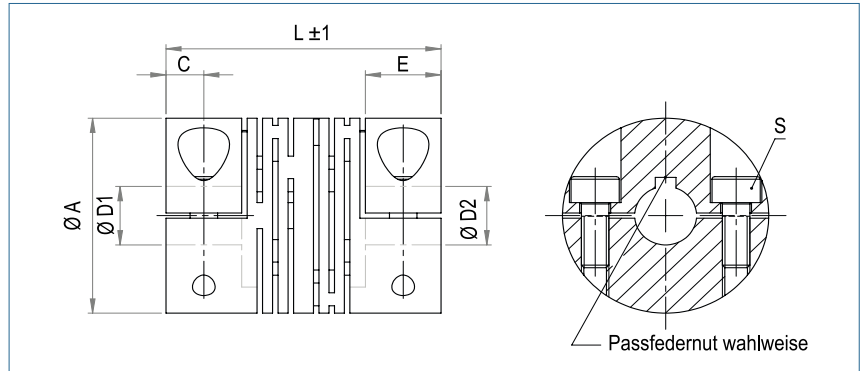

Bestellbeispiel

KBFH / 40 - 10 - 16 - VA

Typ / Größe

ØD1
(H7)

ØD2
(H7)

Material

Größe	Drehmoment TKN (Nm) AL	Drehmoment TKN (Nm) VA	Abmessungen (mm)					Technische Daten										
			L Länge	Ø A Außen- durch- messer	D1/D2 Bohrungen (H7) von~bis	E	C	S Schraube (ISO4762) TA (Nm)	Masse (kg) AL	Masse (kg) VA	Massen- trägheits- moment J AL (g m ²)	Massen- trägheits- moment J VA (g m ²)	Federsteifigkeit		Versatz			max Drehzahl min-1
												Torsion CT 10 ³ (Nm/rad) AL	Torsion CT 10 ³ (Nm/rad) VA	radial ΔKr (mm)	axial ΔKa (mm)	Winkel ΔKw (°)		
30	10	25	40	30	6-14	11	5.5	M4x10 3.4	50	160	0.00680	0.01860	0.868	2.530	0.1	0.85	1.0	6000
40	19	36	48	40	6-19	11	5.5	M5x14 7	115	340	0.02790	0.07580	3.767	11.008	0.15	0.85	1.0	5000
50	35	73	65	50	10-26	19	9.5	M6x16 14	250	650	0.08970	0.24600	7.196	20.995	0.15	0.7	1.5	5000
60	70	110	80	60	10-30	25	12.5	M8x18 27	500	1150	0.25370	0.69400	12.750	37.165	0.15	0.7	1.5	4500
70	130	190	95	70	15-35	25	12.5	M8x25 27	750	1753	0.50660	1.38000	66.768	196.024	0.1	0.33	1.0	4000
80	180	240	100	80	20-40	25	12.5	M8x30 27	1040	2330	0.96240	2.62000	78.189	229.524	0.1	0.33	1.0	3500



- Material** Kupplung: Aluminium oder Edelstahl
- Nabe** Bohrungstoleranz: H7
- Passfedernut** wahlweise nach DIN 6885
- Sondermaterialien auf Anfrage.**

Schalenkupplungen

KBST

Schalenkupplung
einfach geschlitzt



57/58

KBST - VA

Schalenkupplung
einfach geschlitzt, Edelstahl



59/60

KBST - G

Schalenkupplung
geteilt



61/62

KBST - G - VA

Schalenkupplung
geteilt, Edelstahl



63/64

Schalenkupplungen

einfach geschlitz

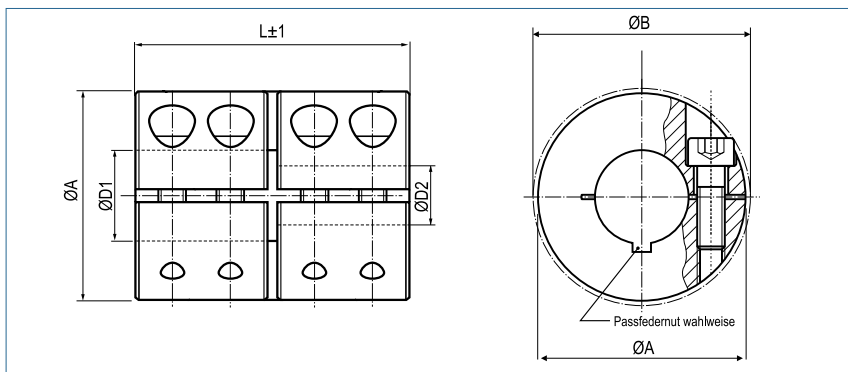

Bestellbeispiel für Standardkupplung

KBST - 50

Diese Kupplung wird automatisch mit durchgängiger Bohrung 50H7 geliefert.

Typ Größe

Bestellbeispiel für Kupplung mit unterschiedlichen Bohrungen

KBST - 50 - 45 - 48

Diese Kupplung entspricht den Abmessungen der KBST-50 und wird mit der Bohrungskombination 45H7 - 48H7 geliefert.

Typ Größe D1 D2

KBST Schalenkupplung - Stahl brüniert									
Größe	Drehmoment Stahl Nm	Abmessungen					Schrauben (ISO4762)	Anzugsmoment der Schrauben Nm	Gewicht g
		Standard-bohrung D1 / D2 H7	abgesetzte Bohrung von-bis	A mm	B mm	L mm			
6	30	6	5-7	18	21.2	30	M3x8	2	47
8	50	8	5-12	24	26.8	35	M3x10	3	102
10	100	10	5-15	29	32.7	45	M4x12	4.5	185
12	100	12	5-15	29	32.7	45	M4x12	4.5	180
14	190	14	10-17	34	39.1	50	M5x16	9	272
15	190	15	10-17	34	39.1	50	M5x16	9	266
16	190	16	10-17	34	39.1	50	M5x16	9	261
20	350	20	10-24	42	48.2	65	M6x16	15	518
25	390	25	10-26	45	50.8	75	M6x16	15	623
30	475	30	20-32	53	58.1	83	M6x18	15	920
35	1100	35	20-40	67	74.1	95	M8x25	40	1880
40	1325	40	30-50	77	83.4	108	M8x25	40	2710
50	2250	50	40-52	85	93.2	124	M10x25	84	3520

Reibschlußmoment (Nm) bei Bohrungsdurchmesser (mm)																							
Größe	5	6	8	10	12	14	16	18	20	22	24	26	28	30	32	34	36	38	40	44	46	48	50
6	18	19																					
8	25	26	29	31	33																		
10	51	53	57	61	65	69																	
12	51	53	57	61	65	69																	
14				109	116	122	129																
15				109	116	122	129																
16				109	116	122	129																
20				195	205	214	223	233	242	251	261												
25				209	219	228	237	247	256	265	275	284											
30									284	293	303	312	321	330	340								
35									582	599	616	632	649	666	682	699	716	732	749				
40														749	765	782	799	815	832	865	882	899	915
50																			1400	1453	1479	1506	1532

+ Passfedernut nach DIN 6885/1 sind nur bei durchgängigen Bohrungen möglich.

Schalenkupplungen

einfach geschlitzt

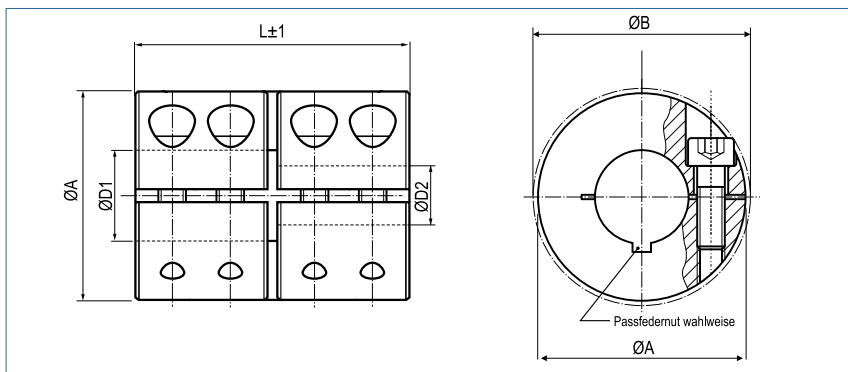

Bestellbeispiel für Standardkupplung

KBST - 80

Diese Kupplung wird automatisch mit durchgängiger Bohrung 50H7 geliefert.

Typ Größe

Bestellbeispiel für Kupplung mit unterschiedlichen Bohrungen

KBST - 80 - 45 - 48

Diese Kupplung entspricht den Abmessungen der KBST-50 und wird mit der Bohrungskombination 45H7 - 48H7 geliefert.

Typ Größe D1 D2

KBST Schalenkupplung - Stahl brüniert									
Größe	Drehmoment Stahl Nm	Abmessungen					Schrauben (ISO4762)	Anzugsmoment der Schrauben Nm	Gewicht g
		Standard-bohrung D1 / D2 H7	abgesetzte Bohrung von~bis	A mm	B mm	L mm			
55	3000	55	45-58	93	99.5	140	M10x30	84	4240
60	3300	60	50-64	100	105	150	M10x30	84	5100
65	4000	65	60-72	115	120	200	M12x35	144	9350
70	4800	70	65-78	122	125.5	220	M12x40	144	11510
75	5500	75	70-88	133	136	220	M12x40	144	12550
80	6800	80	75-92	138	140	220	M12x45	144	13670
85	7500	85	75-92	148	155	250	M16x45	354	19550
90	8400	90	80-100	157	162	280	M16x50	354	23990
95	10000	95	80-100	167	176	300	M20x55	590	31080
100	12500	100	80-104	173	181	320	M20x55	590	35590

Reibschlußmoment (Nm) bei Bohrungsdurchmesser (mm)																				
Größe	45	48	50	52	55	58	60	64	65	70	72	75	78	80	85	88	90	95	100	104
55	1572	1611	1638	1664	1704	1743														
60			1717	1743	1783	1823	1849	1902												
65							2886	2963	2982	3078	3117									
70									3098	3194	3232	3290	3348							
75										3425	3463	3521	3579	3617	3713	3771				
80												3598	3656	3694	3790	3848	3886			
85												6758	6867	6939	7120	7228	7300			
90														7228	7409	7517	7589	7770	7951	
95														9865	10107	10252	10349	10591	10833	
100														10156	10397	10542	10639	10881	11123	11316

+ Passfedernuten nach DIN 6885/1 sind nur bei durchgängigen Bohrungen möglich.

Schalenkupplungen

einfach geschlitzit, in Edelstahl

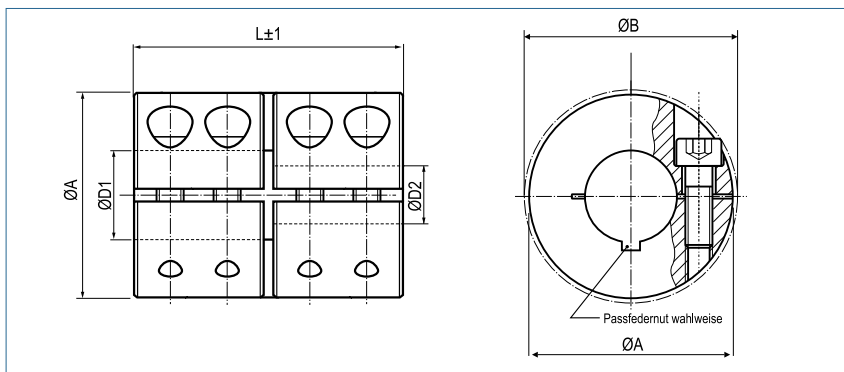

Bestellbeispiel für Standardkupplung

KBST-VA - 50

Diese Kupplung wird automatisch mit durchgängiger Bohrung 50H7 geliefert.

Typ Größe

Bestellbeispiel für Kupplung mit unterschiedlichen Bohrungen

KBST-VA - 50 - 45 - 48

Diese Kupplung entspricht den Abmessungen der KBST-50 und wird mit der Bohrungskombination 45H7 - 48H7 geliefert.

Typ Größe D1 D2

Schalenkupplung - Edelstahl rostfrei									
Größe	Drehmoment Edelstahl Nm	Abmessungen					Schrauben (ISO4762)	Anzugsmoment der Schrauben Nm	Gewicht g
		Standardbohrung D1 / D2 H7	abgesetzte Bohrungen von-bis	A mm	B mm	L mm			
6	25	6	5-7	18	21.2	30	M3x8	1.6	47
8	40	8	5-12	24	26.8	35	M3x10	1.6	102
10	90	10	5-15	29	32.7	45	M4x12	3.9	185
12	90	12	5-15	29	32.7	45	M4x12	3.9	180
14	160	14	10-17	34	39.1	50	M5x16	7.6	272
15	160	15	10-17	34	39.1	50	M5x16	7.6	266
16	160	16	10-17	34	39.1	50	M5x16	7.6	261
20	300	20	10-24	42	48.2	65	M6x16	13.2	518
25	325	25	10-26	45	50.8	75	M6x16	13.2	623
30	400	30	20-32	53	58.1	83	M6x18	13.2	920
35	925	35	20-40	67	74.1	95	M8x25	32	1880
40	1100	40	30-50	77	83.4	108	M8x25	32	2710
50	1875	50	40-52	85	93.2	124	M10x25	63	3520

Reibschlußmoment (Nm) bei Bohrungsdurchmesser (mm)																					
Größe	5	6	8	10	12	14	18	20	24	26	28	30	32	38	40	42	44	46	48	50	52
6	15	16																			
8	21	22	23	25	27																
10	44	45	49	52	56	59															
12	44	45	49	52	56	59															
14				93	98	104															
15				93	98	104															
16				93	98	104															
20				167	175	183	199	207	223												
25				179	187	195	211	219	235	243											
30								243	259	267	274	282	290								
35								510	539	553	568	582	597	641	655						
40												655	670	713	728	743	757	772	786	801	
50															1226	1250	1273	1296	1319	1342	1365

+ Passfedernuten nach DIN 6885/1 sind nur bei durchgängigen Bohrungen möglich.

Schalenkupplungen

einfach geschlitzt, in Edelstahl

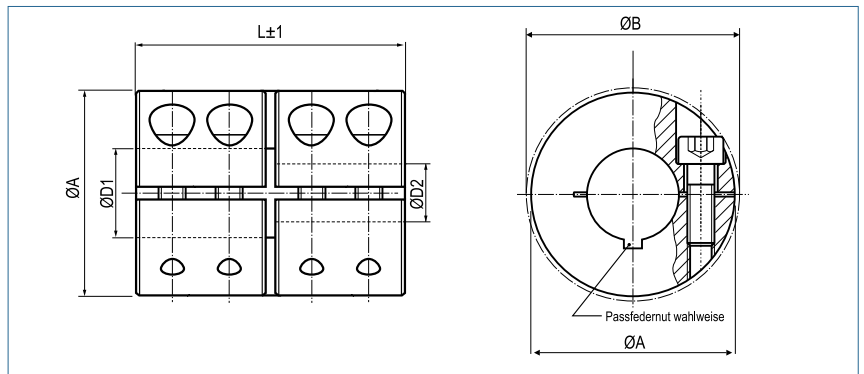

Bestellbeispiel für Standardkupplung

KBST-VA - 80

Typ Größe

Diese Kupplung wird automatisch mit durchgängiger Bohrung 50H7 geliefert.

Bestellbeispiel für Kupplung mit unterschiedlichen Bohrungen

KBST-VA - 80 - 45 - 48

Typ Größe D1 D2

Diese Kupplung entspricht den Abmessungen der KBST-50 und wird mit der Bohrungskombination 45H7 - 48H7 geliefert.

Schalenkupplung - Edelstahl rostfrei									
Größe	Drehmoment Edelstahl Nm	Abmessungen					Schrauben (ISO4762)	Anzugsmoment der Schrauben Nm	Gewicht g
		Standard- bohrung D1 / D2 H7	abgesetzte Bohrungen von-bis	A mm	B mm	L mm			
55	2500	55	45-58	93	99.5	140	M10x30	63	4240
60	2750	60	50-64	100	105	150	M10x30	63	5100
65	3335	65	60-72	115	120	200	M12x35	108	9350
70	4000	70	65-78	122	125.5	220	M12x40	108	11510
75	4585	75	70-88	133	136	220	M12x40	108	12550
80	5660	80	75-92	138	140	220	M12x45	108	13670
85	6250	85	75-92	148	155	250	M16x45	264	19550
90	7000	90	80-100	157	162	280	M16x50	264	23990
95	8335	95	80-100	167	176	300	M20x55	363	31080
100	10400	100	80-104	173	181	320	M20x55	363	35590

Reibschlußmoment (Nm) bei Bohrungsdurchmesser (mm)																				
Größe	45	48	50	52	55	58	60	64	65	70	72	75	78	80	85	88	90	95	100	104
55	1392	1427	1451	1474	1509	1544														
60			1521	1544	1580	1615	1638	1685												
65							1755	1802	1814	1872	1895									
70									1884	1942	1966	2001	2036							
75										2083	2106	2141	2176	2200	2258	2293				
80												2188	2223	2246	2305	2340	2363			
85												5932	6027	6090	6249	6344	6407			
90														6344	6503	6598	6661	6820	6978	
95														7107	7282	7386	7456	7630	7804	
100														7316	7491	7595	7665	7839	8013	8153

+ Passfedernuten nach DIN 6885/1 sind nur bei durchgängigen Bohrungen möglich.

Schalenkupplungen

geteilt

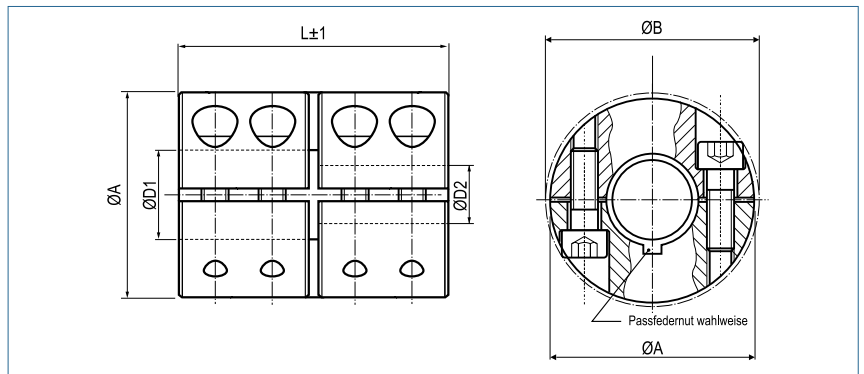

Bestellbeispiel für Standardkupplung

KBST-G - 50

Typ Größe

Diese Kupplung wird automatisch mit durchgängiger Bohrung 50H7 geliefert.

Bestellbeispiel für Kupplung mit unterschiedlichen Bohrungen

KBST-G - 50 - 45 - 48

Typ Größe D1 D2

Diese Kupplung entspricht den Abmessungen der KBST-G-50 und wird mit der Bohrungskombination 45H7 - 48H7 geliefert.

Schalenkupplung geteilt - Stahl brüniert									
Größe	Drehmoment Stahl Nm	Abmessungen					Schrauben (ISO4762)	Anzugsmoment der Schrauben Nm	Gewicht g
		Standardbohrung D1 / D2 H7	abgesetzte Bohrung von-bis	A mm	B mm	L mm			
6	30	6	5-7	18	21.2	30	M3x8	2	47
8	50	8	5-12	24	26.8	35	M3x10	3	102
10	100	10	5-15	29	32.7	45	M4x12	4.5	185
12	100	12	5-15	29	32.7	45	M4x12	4.5	180
14	190	14	10-17	34	39.1	50	M5x16	9	272
15	190	15	10-17	34	39.1	50	M5x16	9	266
16	190	16	10-17	34	39.1	50	M5x16	9	261
20	350	20	10-24	42	48.2	65	M6x16	15	518
25	390	25	10-26	45	50.8	75	M6x16	15	623
30	475	30	20-32	53	58.1	83	M6x18	15	920
35	1100	35	20-40	67	74.1	95	M8x25	40	1880
40	1325	40	30-50	77	83.4	108	M8x25	40	2710
50	2250	50	40-52	85	93.2	124	M10x25	84	3520

Reibschlußmoment (Nm) bei Bohrungsdurchmesser (mm)																					
Größe	5	6	8	10	12	14	16	18	20	22	26	28	30	32	34	38	42	44	48	50	52
6	29	35																			
8	29	35	47	58	70																
10	52	62	83	103	124	145															
12	52	62	83	103	124	145															
14				168	202	235	269														
15				168	202	235	269														
16				168	202	235	269														
20				237	284	332	379	427	474	521											
25				237	284	332	379	427	474	521	616										
30									474	521	616	664	711	758							
35									847	932	1102	1186	1271	1356	1441	1610					
40													1271	1356	1441	1610	1780	1864	2034	2119	
50																	2825	2960	3229	3363	3498

+ Passfedernuten nach DIN 6885/1 sind bei allen Bohrungskombinationen möglich.

Schalenkupplungen

geteilt

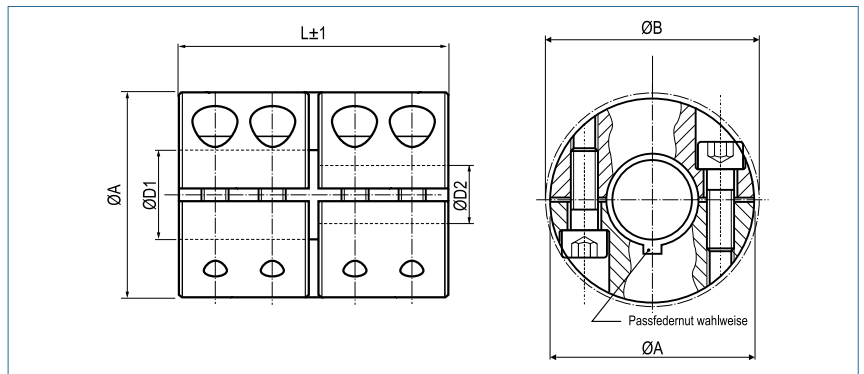

Bestellbeispiel für Standardkupplung

KBST-G - 80

Typ

Größe

Diese Kupplung wird automatisch mit durchgängiger Bohrung 50H7 geliefert.

Bestellbeispiel für Kupplung mit unterschiedlichen Bohrungen

KBST-G - 80 - 45 - 48

Typ

Größe

D1

D2

Diese Kupplung entspricht den Abmessungen der KBST-G-50 und wird mit der Bohrungskombination 45H7 - 48H7 geliefert.

Schalenkupplung geteilt - Stahl brüniert									
Größe	Drehmoment Stahl Nm	Abmessungen					Schrauben (ISO4762)	Anzugsmoment der Schrauben Nm	Gewicht g
		Standard- bohrung D1 / D2 H7	abgesetzte Bohrung von-bis	A mm	B mm	L mm			
55	3000	55	45-58	93	99.5	140	M10x30	84	4015
60	3300	60	50-64	100	105	150	M10x30	84	4860
65	4000	65	60-72	115	120	200	M12x35	144	8960
70	4800	70	65-78	122	125.5	220	M12x40	144	10900
75	5500	75	70-88	133	136	220	M12x40	144	12390
80	6800	80	75-92	138	140	220	M12x45	144	13170
85	7500	85	75-92	148	155	250	M16x45	354	18680
90	8400	90	80-100	157	162	280	M16x50	354	23080
95	10000	95	80-100	167	176	300	M20x55	590	29530
100	12500	100	80-104	173	181	320	M20x55	590	33990

Reibschlußmoment (Nm) bei Bohrungsdurchmesser (mm)																				
Größe	45	48	50	52	55	58	60	64	65	70	72	75	78	80	85	88	90	95	100	104
55	3144	3223	3276	3328	3408	3487														
60			3434	3487	3566	3645	3698	3804												
65							5772	5926	5964	6157	6234									
70									6195	6388	6465	6580	6696							
75										6849	6926	7042	7157	7234	7427	7542				
80												7196	7311	7388	7581	7696	7773			
85												13516	13733	13878	14239	14456	14601			
90														14456	14817	15034	15179	15540	15902	
95														19731	20214	20505	20698	21182	21665	
100														20311	20795	21085	21278	21762	22246	22632



Passfedernuten nach DIN 6885/1 sind bei allen Bohrungskombinationen möglich.

Schalenkupplungen

geteilt, in Edelstahl

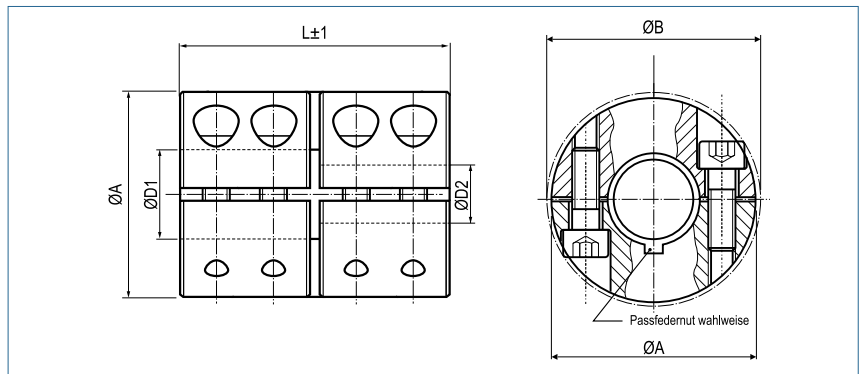

Bestellbeispiel für Standardkupplung

KBST-G-VA - 50

Diese Kupplung wird automatisch mit durchgängiger Bohrung 50H7 geliefert.

Typ

Größe

Bestellbeispiel für Kupplung mit unterschiedlichen Bohrungen

KBST-G-VA - 50 - 45 - 48

Diese Kupplung entspricht den Abmessungen der KBST-G-50 und wird mit der Bohrungskombination 45H7 - 48H7 geliefert.

Typ

Größe

D1

D2

KBST - G - VA Schalenkupplung geteilt - Edelstahl rostfrei									
Größe	Drehmoment Edelstahl Nm	Abmessungen					Schrauben (ISO4762)	Anzugsmoment der Schrauben Nm	Gewicht g
		Standard-bohrung D1 / D2 H7	abgesetzte Bohrungen von-bis	A mm	B mm	L mm			
6	25	6	5-7	18	21.2	30	M3x8	1.6	47
8	40	8	5-12	24	26.8	35	M3x 10	1.6	102
10	90	10	5-15	29	32.7	45	M4x 12	3.9	185
12	90	12	5-15	29	32.7	45	M4x 12	3.9	180
14	160	14	10-17	34	39.1	50	M5x 16	7.6	272
15	160	15	10-17	34	39.1	50	M5x 16	7.6	266
16	160	16	10-17	34	39.1	50	M5x 16	7.6	261
20	300	20	10-24	42	48.2	65	M6x 16	13.2	518
25	325	25	10-26	45	50.8	75	M6x 16	13.2	623
30	400	30	20-32	53	58.1	83	M6x 18	13.2	920
35	925	35	20-40	67	74.1	95	M8x 25	32	1880
40	1100	40	30-50	77	83.4	108	M8x 25	32	2710
50	1875	50	40-52	85	93.2	124	M10x 25	63	3520

Reibschlußmoment (Nm) bei Bohrungsdurchmesser (mm)																				
Größe	5	6	12	14	16	18	20	22	24	28	30	32	34	36	38	40	44	46	50	52
6	24	29																		
8	24	29	57																	
10	44	53	106	124																
12	44	53	106	124																
14			172	200	229															
15			172	200	229															
16			172	200	229															
20			243	284	324	365	405	446	486											
25			243	284	324	365	405	446	486											
30							405	446	486	567	608	648								
35							742	816	890	1038	1112	1186	1261	1335	1409	1483				
40											1112	1186	1261	1335	1409	1483	1631	1706	1854	
50																2357	2593	2711	2946	3064

+ Passfedernuten nach DIN 6885/1 sind bei allen Bohrungskombinationen möglich.

Schalenkupplungen

geteilt, in Edelstahl

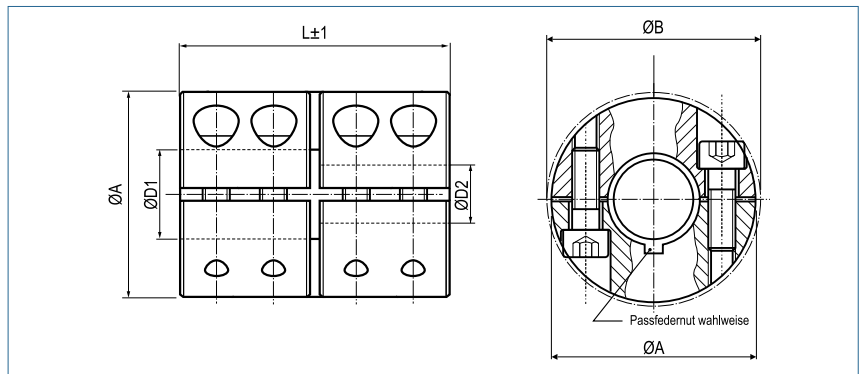

Bestellbeispiel für Standardkupplung

KBST-G-VA - 85

Typ

Größe

Diese Kupplung wird automatisch mit durchgängiger Bohrung 50H7 geliefert.

Bestellbeispiel für Kupplung mit unterschiedlichen Bohrungen

KBST-G-VA - 85 - 45 - 48

Typ

Größe

D1

D2

Diese Kupplung entspricht den Abmessungen der KBST-G-50 und wird mit der Bohrungskombination 45H7 - 48H7 geliefert.

Schalenkupplung geteilt - Stahl brüniert									
Größe	Drehmoment Stahl Nm	Abmessungen					Schrauben (ISO4762)	Anzugsmoment der Schrauben Nm	Gewicht g
		Standard- bohrung D1 / D2 H7	abgesetzte Bohrung von-bis	A mm	B mm	L mm			
55	2500	55	45-58	93	99.5	140	M10x30	63	4015
60	2750	60	50-64	100	105	150	M10x30	63	4860
65	3335	65	60-72	115	120	200	M12x35	108	8960
70	4000	70	65-78	122	125.5	220	M12x40	108	10900
75	4585	75	70-88	133	136	220	M12x40	108	12390
80	5660	80	75-92	138	140	220	M12x45	108	13170
85	6250	85	75-92	148	155	250	M16x45	264	18680
90	7000	90	80-100	157	162	280	M16x50	264	23080
95	8335	95	80-100	167	176	300	M20x55	363	29530
100	10400	100	80-104	173	181	320	M20x55	363	33990

Reibschlußmoment (Nm) bei Bohrungsdurchmesser (mm)																				
Größe	45	48	50	52	55	58	60	64	65	70	72	75	78	80	85	88	90	95	100	104
55	2785	2855	2902	2948	3019	3089														
60			3042	3089	3159	3229	3276	3370												
65							3510	3604	3627	3744	3791									
70									3767	3884	3931	4001	4072							
75										4165	4212	4282	4352	4399	4516	4586				
80												4376	4446	4493	4610	4680	4727			
85												11863	12054	12180	12498	12688	12815			
90														12688	13005	13196	13322	13640	13957	
95														14215	14563	14772	14912	15260	15608	
100														14633	14981	15190	15330	15678	16026	16305



Passfedernuten nach DIN 6885/1 sind bei allen Bohrungskombinationen möglich.

Klemmringe

KR | 4 ~ 50

Klemmring
geschlitzt

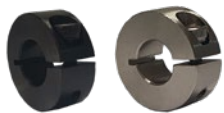

S. 66

KR-G | 4 ~ 50

Klemmring
geteilt



S. 67

Klemmring

geschlitzt

optional komplett
in Edelstahl

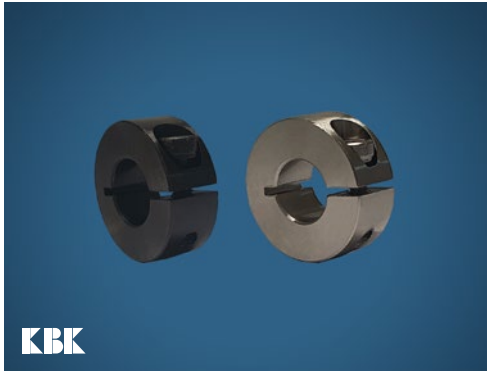

KBK

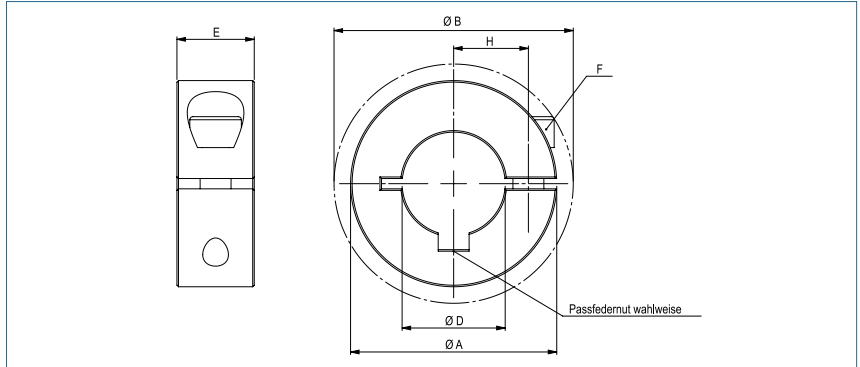

Bestellbeispiel

KR - 28 **Stahl brüniert**

Typ Größe

Bestellbeispiel

KR-VA - 28 **Edelstahl**

Typ Größe

Klemmring geschlitzt

Größe	Axialkraft N		Abmessungen					F Schrauben (ISO4762)	Anzugsmoment der Schrauben Nm		Gewicht g
	Stahl	Edelstahl (VA)	Standard- bohrung D / H7	A mm	H mm	E mm	B mm		Stahl	Edelstahl (VA)	
4	1525	867	4	16	5	9	20.7	M3x8	2	1.3	0.010
5	1525	867	5	16	5	9	20.7	M3x8	2	1.3	0.011
6	1525	867	6	16	5	9	20.7	M3x8	2	1.3	0.011
8	1525	867	8	18	6	9	22.4	M3x8	2	1.3	0.012
10	1335	758	10	24	8	9	26	M3x10	2	1.3	0.022
12	2415	1398	12	28	9.5	11	31.8	M4x12	5	3	0.039
15	3940	2288	15	34	12	13	39.4	M5x16	10	6	0.065
16	3940	2288	16	34	12	13	39.4	M5x16	10	6	0.063
18	3803	2208	18	36	13	13	41.1	M5x16	10	6	0.069
20	5540	4612	20	40	14.5	15	46.4	M6x18	15	10	0.097
22	5378	4477	22	42	15.5	15	48.1	M6x18	15	10	0.103
25	5236	4358	25	45	16.5	15	50.8	M6x18	15	10	0.144
28	5053	4206	28	48	18	15	53.7	M6x18	15	10	0.123
30	4809	4003	30	54	21	15	58.6	M6x18	15	10	0.163
40	4468	3719	40	60	25	15	65	M6x18	15	10	0.163
50	8135	4729	50	78	32	19	87	M8x25	42	25	0.386



Bohrungstoleranz H7
Material Stahl brüniert
 Edelstahl blank
Passfedernut wahlweise nach DIN 6885
Temperaturbereich -40 °C ~ 175 °C

Klemmring

geteilt

optional komplett
in Edelstahl

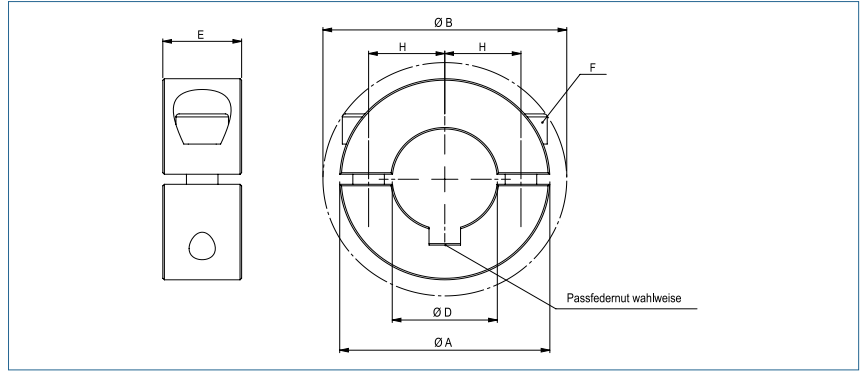
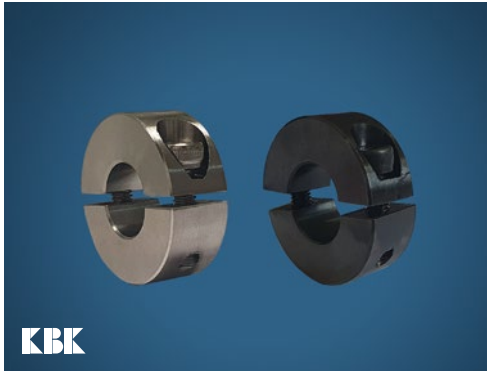

Bestellbeispiel **KR-G - 28** Stahl brüniert

Typ Größe

Bestellbeispiel **KR-G-VA - 28** Edelstahl

Typ Größe

Klemmring geteilt											
Größe	Axialkraft N		Abmessungen					F Schrauben (ISO4762)	Anzugsmoment der Schrauben Nm		Gewicht kg
	Stahl	Edelstahl (VA)	Standardbohrung D / H7	A mm	H mm	E mm	B mm		Stahl	Edelstahl (VA)	
4	2288	1300	4	16	5	9	20.7	M3x8	2	1.3	0.011
5	2288	1300	5	16	5	9	20.7	M3x8	2	1.3	0.011
6	2288	1300	6	16	5	9	20.7	M3x8	2	1.3	0.010
8	2288	1300	8	18	6	9	22.4	M3x8	2	1.3	0.012
10	2288	1300	10	24	8	9	26	M3x10	2	1.3	0.022
12	3952	2288	12	28	9.5	11	31.8	M4x12	5	3	0.038
15	6448	3744	15	34	12	13	39.4	M5x16	10	6	0.065
16	6448	3744	16	34	12	13	39.4	M5x16	10	6	0.063
18	6448	3744	18	36	13	13	41.1	M5x16	10	6	0.069
20	9308	7748	20	40	14.5	15	46.4	M6x18	15	10	0.097
22	9308	7748	22	42	15.5	15	48.1	M6x18	15	10	0.103
25	9308	7748	25	45	16.5	15	50.8	M6x18	15	10	0.114
28	9308	7748	28	48	18	15	53.7	M6x18	15	10	0.123
30	9308	7748	30	54	21	15	58.6	M6x18	15	10	0.163
40	9308	7748	40	60	25	15	65	M6x18	15	10	0.163
50	14560	9672	50	78	32	19	87	M8x25	32	25	0.386

+ Bohrungstoleranz	H7
Material	Stahl brüniert Edelstahl blank
Passfedernut	wahlweise nach DIN 6885
Temperaturbereich	-40 °C ~ 175 °C

Fragen Sie uns nach unseren Katalogen
für **SICHERHEITSKUPPLUNGEN**, **WELLE-NABE-VERBINDUNGEN**
und **MAGNETKUPPLUNGEN**

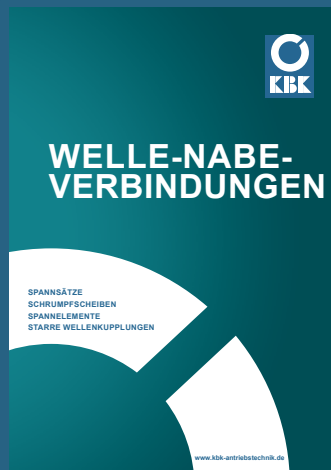

KBK Antriebstechnik GmbH

Unterlandstraße 46

63911 Klingenberg am Main

Tel.: +49 9372 94061-0

Fax: +49 9372 94061-29

info@kbk-antriebstechnik.de

www.kbk-antriebstechnik.de