

Stromag TRI-R Highly-Flexible Ring Coupling

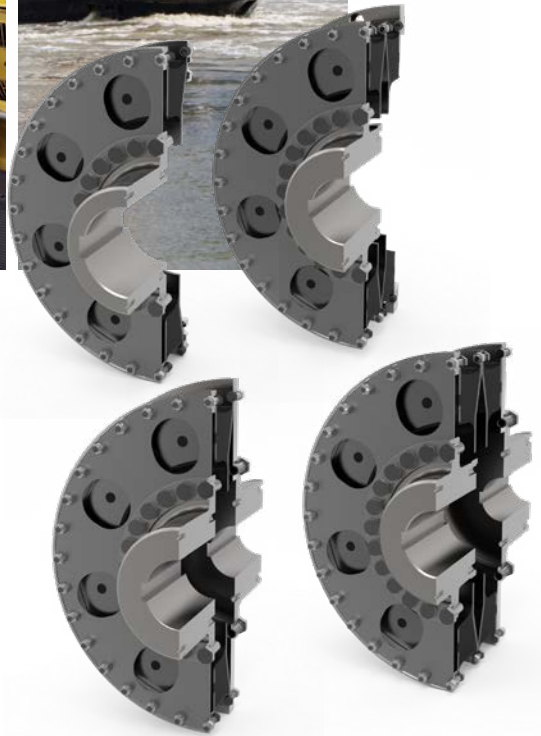

Stromag

Founded in 1932, Stromag has grown to become a globally recognized leader in the development and manufacture of innovative power transmission components for industrial drivetrain applications. Stromag engineers utilize the latest design technologies and materials to provide creative, energy-efficient solutions that meet their customer's most challenging requirements.

Stromag's extensive product range includes flexible couplings, disc brakes, limit switches, an array of hydraulically, pneumatically, and electrically actuated brakes, and a complete line of electric, hydraulic and pneumatic clutches.

Stromag engineered solutions improve drivetrain performance in a variety of key markets including energy, off-highway, metals, marine, transportation, printing, textiles, and material handling on applications such as wind turbines, conveyor systems, rolling mills, agriculture and construction machinery, municipal vehicles, forklifts, cranes, presses, deck winches, diesel engines, gensets and stage machinery.

VISIT US ON THE WEB AT STROMAG.COM



Altra Motion

Altra is a leading global designer and producer of a wide range of electromechanical power transmission and motion control components and systems. Providing the essential control of equipment speed, torque, positioning, and other functions, Altra products can be used in nearly any machine, process or application involving motion. From engine braking systems for heavy duty trucks to precision motors embedded in medical robots to brakes used on offshore wind turbines, Altra has been serving customers around the world for decades.

Altra's leading brands include **Ameridrives**, **Bauer** Gear Motor, **Bibby** Turboflex, **Boston** Gear, **Delevan**, **Delroyd** Worm Gear, **Formsprag** Clutch, **Guardian** Couplings, **Huco**, **Jacobs** Vehicle Systems, **Kilian**, **Kollmorgen**, **Lamiflex** Couplings, **Marland** Clutch, **Matrix**, **Nuttall** Gear, **Portescap**, **Stieber**, **Stromag**, **Svendborg** Brakes, **TB Wood's**, **Thomson**, **Twiflex**, **Warner** Electric and **Wichita** Clutch.

VISIT US ON THE WEB AT ALTRAMOTION.COM



CONTENT

STROMAG TRI-R COUPLINGS: **III**

COUPLING AT A GLANCE	4
Product range	
Benefits include	
Applications areas	
Fail-safe device	
Classifications	
Torque range	
Instruction for the designer	
Use in potentially explosive environments	
The torsional vibration analysis	
OUTPUT TABLE	10
SERIES TEF...W-R	12
SERIES TEW...W-R	16
SERIES TEF...W-RR	18
SERIES TEW...W-RR	20
Characteristic	24
Coupling Design, question sheet	27
Use in potentially explosive environments, question sheet	28

STROMAG TRI-R COUPLINGS PRODUCT RANGE

TEF...W – R SERIES

Nominal torque range: 1300 – 63,000 Nm

Front perspective



back perspective



TEW...W – R SERIES

Nominal torque range: 1300 – 63,000 Nm

Front perspective



back perspective

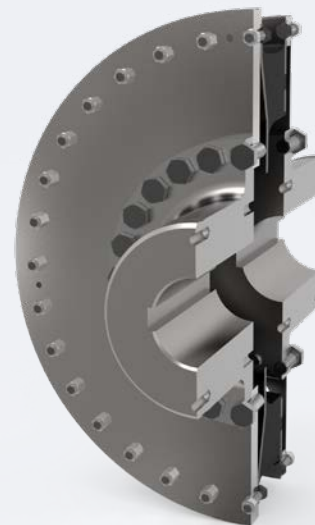

TEF...W – RR SERIES

Nominal torque range: 1300 – 63,000 Nm

Front perspective



back perspective



TEW...W – RR SERIES

Nominal torque range: 1300 – 63,000 Nm

Front perspective



back perspective



STROMAG TRI-R COUPLINGS

BENEFITS INCLUDE

- Stromag TRI-R Couplings are highly flexible rubber couplings with linear spring characteristic ideal for diesel engine and resiliently mounted drives.
- Allows a simple connection of a flange, e.g. a flywheel, with a shaft. Shaft to shaft and flange to flange combinations are also available.
- Covers the torque range from 1.3 to 63 kNm. The couplings up to 16.000 Nm, the outer connection dimensions conform as a standard to the flywheel connections of the SAE standard J620. The larger couplings are basically designed with metric flywheel connections.
- Stromag TRI-R coupling allows an offset in all directions by using a combination of rubber-flexible ring element and a diaphragm of spring steel.
- Various stiffnesses and multi-row combinations of ring elements are available to get the perfect fit for your application.
- Stromag TRI-R Couplings are available with a fail-safe device.

APPLICATION AREAS



- The Stromag TRI-R Coupling is designed for applications with piston engines. The ring element can be bolted directly to the flywheel of an engine or compressor.
- Due to its high axial and radial offset capacity, the coupling is ideal for applications with resiliently mounted drives.

FAIL-SAFE DEVICE

The Stromag TRI-R coupling is available with a fail-safe device. A rupture in the flexible element causes claws to intermesh, forming a torsionally rigid, backlash connection between the drive and output sides. Temporary emergency operation is possible with limited torque. The permissible torques and speeds must be calculated separately on the basis of torsional vibrations transferred via a torsionally rigid structure. For marine main drives, some classification societies require the use of emergency operation devices.

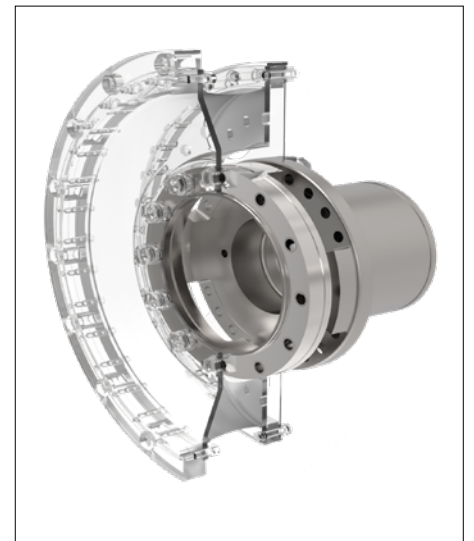

Stromag – Flexible Couplings

COUPLING AT A GLANCE

CLASSIFICATIONS



For survey of the coupling by a classification society, the regulations of the society have to be adhered to. The coupling characteristics may differ from the definitions given in this catalogue. Accordingly prepared data sheets are available on request.

A number of classification societies prescribe fail-safe devices on ships main drives.

TORQUE RANGE

- 1300 up to 63,000 Nm
(higher torque range on request could be possible)

INSTRUCTIONS FOR THE DESIGNER

The metal parts of Stromag TRI-R coupling are made of steel. The ring element is made of different elastomer materials in various torsional stiffnesses.

The design with natural rubber (NR) can be used within the temperature range from -50 °C up to +80 °C.

Damping work may cause the flexible element to reach temperatures higher than ambient. This must be considered when the coupling is to be fitted with a guard or cowl, and adequate ventilation and heat dissipation must be provided.

The Stromag TRI-R coupling can be delivered with EN 10204 acceptance as defined in the classification societies rules.

When stored properly, flexible rubber elements retain their properties over several years. It is essential here that the stored parts are protected against oxygen, ozone, light, heat, moisture, and solvents. Solvents, fuels, lubricants, chemicals, acids, disinfectants, and similar may not be stored in the same room. The storage temperature should not be lower than +10°C and not higher than +25°C.

All UV light sources are harmful and must be avoided. Equipment that generates ozone, e.g. light sources and electric motors, must be kept away from the storage location. The relative air humidity should not exceed 65 %.

Further details can be taken from DIN 7716 and ISO 2230.

USE IN POTENTIALLY EXPLOSIVE ENVIROMENTS



The coupling conforms to the requirements under Directive 2014/34/EU and can be used as follows:

- a. Zone 1** (gas, Category 2G) in Groups IIA, IIB, and IIC, T4
- b. Zone 2** (gas, Category 3G) in Groups IIA, IIB, and IIC, T4
- c. Zone 22** (dust, Category 3D) for dusts with a minimum ignition energy > 3 mJ, T 125°C

Stromag TRI-R couplings compliance with the requirements for each of these zones / categories is documented in the form of the following codes on our products:

Use in gas atmospheres:

CE II 2G Ex h IIC (T4) Gb

Use in dust atmospheres:

CE II 3D Ex h IIIC T120°C Dc

Use in potentially explosive environments must be based on the request form annexed to this catalogue.

THE TORSIONAL VIBRATION ANALYSIS



Stromag's Know-how in Torsional Vibration Analysis (TVA) constitutes the core of each coupling design. It provides a comprehensive analysis of loads in the crankshaft, coupling and driven side to ensure that no critical speeds occur during operation.

Unevenly rotating systems can severely degrade product quality and cause great harm to the powertrain. On a daily basis, the TVA experts at Stromag work on the challenge of detecting such deviations by measuring them and protecting the entire powertrain with ideal product selection. Stromag is capable of calculating stationary and transient operating conditions considering the stiffness and damping of the elastomers.

Stromag – Flexible Couplings

TRI-R Highly-Flexible Ring Coupling

Output table						
Coupling size	Nominal torque	Maximum torque		Adm. alternating torque	Adm. speed	Adm. axial displacement
	T_{KN} Nm	T_{Kmax1} ¹⁾ Nm	T_{Kmax2} ²⁾ Nm	T_{KW} Nm	n_{max} min ⁻¹	ΔK_a ³⁾ mm
311 R	1300	1950	3900	325	3800	3
312 R	1700	2550	5100	425	3800	3
313 R	2000	3000	6000	500	3800	3
321 R	1800	2700	5400	450	3800	3
322 R	2200	3300	6600	550	3800	3
323 R	2600	3900	7800	650	3800	3
411 R	2300	3450	6900	575	2800	4
412 R	3000	4500	9000	750	2800	4
413 R	4000	6000	12000	1000	2800	4
421 R	3500	5250	10500	875	2800	4
422 R	3800	5700	11400	950	2800	4
423 R	5200	7800	15600	1300	2800	4
431 R	4400	6600	13200	1100	2800	4
432 R	5600	8400	16800	1400	2800	4
433 R	6700	10050	20100	1675	2800	4
511 R	7200	10800	21600	1800	2300	5
512 R	9400	14100	28200	2350	2300	5
513 R	11400	17100	34200	2850	2300	5
521 R	9800	14700	29400	2450	2300	5
522 R	13000	19500	39000	3250	2300	5
523 R	14800	22200	44400	3700	2300	5
641 R	16000	24000	48000	4000	2100	6
642 R	16000	24000	48000	4000	2100	6
643 R	16000	24000	48000	4000	2100	6
741 R	20000	30000	60000	5000	2000	6
742 R	20000	30000	60000	5000	2000	6
743 R	20000	30000	60000	5000	2000	6
841 R	25000	37500	75000	6250	1900	6
842 R	25000	37500	75000	6250	1900	6
843 R	25000	37500	75000	6250	1900	6
941 R	31500	47250	94500	7875	1750	6
942 R	31500	47250	94500	7875	1750	6
943 R	31500	47250	94500	7875	1750	6
1041 R	40000	60000	120000	10000	1600	6
1042 R	40000	60000	120000	10000	1600	6
1043 R	40000	60000	120000	10000	1600	6
1141 R	50000	75000	150000	12500	1500	6
1142 R	50000	75000	150000	12500	1500	6
1143 R	50000	75000	150000	12500	1500	6
1241 R	63000	94750	189000	15800	1000	7
1242 R	63000	94750	189000	15800	1000	7
1243 R	63000	94750	189000	15800	1000	7

General remark:

Output table is for single rubber element coupling. For dual rubber element coupling the characteristic values for C_r and C_{Tdyn} are only half. The characteristic values for radial displacement and P_{KV} are double.

1) for transient repetitive vibrations during start/stop, clutching etc.

2) for rare occasional peak loads, e.g. short circuits in generators

3) dyn. axial displacement $\Delta K_{a\ dyn} = 0.33 \cdot \Delta K_a$

4) at $n_{max} = 600$ rpm, for higher speed ratings: $\Delta K_r(n) = \sqrt{\frac{600\ \text{rpm}}{n}} \cdot \Delta K_r$

5) at: $TW = 0.2 \cdot T_{KN}$; $T = 0.8 \cdot T_{KN}$; $f = 10$ Hz; $\vartheta = 30^\circ\text{C}$

Axial reaction force	Adm. radial displacement	Adm. max. radial displacement	Radial stiffness	Torsional stiffness	Relative damping	Adm. damping power
F_a 8) kN	ΔK_r 4) 6) mm	ΔK_{rmax} 6) mm	C_r 7) kN/mm	C_{Tdyn} 5) 7) kNm/rad	Ψ 5) 7)	$P_{KV 60}$ 6) 9) W
0.26	3	6	0.38	6.9	0.8	260
0.26	3	6	0.52	9.5	1.0	260
0.26	2	4	0.75	13.5	1.1	260
0.26	3	6	0.49	10.5	0.8	340
0.26	3	6	0.75	14.5	1.0	340
0.26	2	4	1.0	20.0	1.1	340
0.27	4	8	0.59	19.0	0.8	360
0.27	4	8	0.72	28.5	1.0	360
0.27	3	6	1.1	34.5	1.1	360
0.27	4	8	0.78	25.5	0.8	440
0.27	4	8	1.0	34.5	1.0	440
0.27	3	6	1.2	42.0	1.1	440
0.27	4	8	0.94	32.5	0.8	510
0.27	4	8	1.1	42.5	1.0	510
0.27	3	6	1.7	57.5	1.1	510
0.45	5	10	1.1	60.0	0.8	580
0.45	5	10	1.4	82.5	1.0	580
0.45	4	8	2.0	105.0	1.1	580
0.45	5	10	1.8	90.0	0.8	630
0.45	5	10	1.9	100	1.0	630
0.45	4	8	2.4	146	1.1	630
0.60	6	12	1.4	85	0.7	680
0.60	6	12	2.0	120	1.0	680
0.60	6	12	3.6	210	1.1	680
0.90	6	12	1.6	105	0.7	800
0.90	6	12	2.4	160	1.0	800
0.90	6	12	4.2	275	1.1	800
0.92	6	12	1.6	125	0.7	900
0.92	6	12	2.7	210	1.0	900
0.92	6	12	4.5	345	1.1	900
0.92	6	12	1.9	170	0.7	960
0.92	6	12	3.1	275	1.0	960
0.92	6	12	5.1	460	1.1	960
1.1	7	14	2.0	210	0.7	1080
1.1	7	14	3.3	350	1.0	1080
1.1	7	14	5.6	590	1.1	1080
1.1	7	14	2.2	275	0.7	1160
1.1	7	14	3.6	440	1.0	1160
1.1	7	14	6.0	740	1.1	1160
1.6	9	18	2.5	350	0.7	1240
1.6	9	18	4.0	550	1.0	1240
1.6	9	18	6.8	950	1.1	1240

6) For coupling temperatures exceeding 30°C, this value must be reduced by the temperature factor

7) Tolerances until $\pm 15\%$ related to the material are possible

8) at shaft offset $\Delta W_a = 1$ mm

9) The value $P_{KV 60}$ describes the damping power to be absorbed over 1 hour.

Permanently absorbed damping power $P_{KV \infty} = 0.5 \cdot P_{KV 60}$

Stromag – Flexible Couplings

TRI-R Highly-Flexible Ring Coupling

Series TEF...W – R

Figure 1

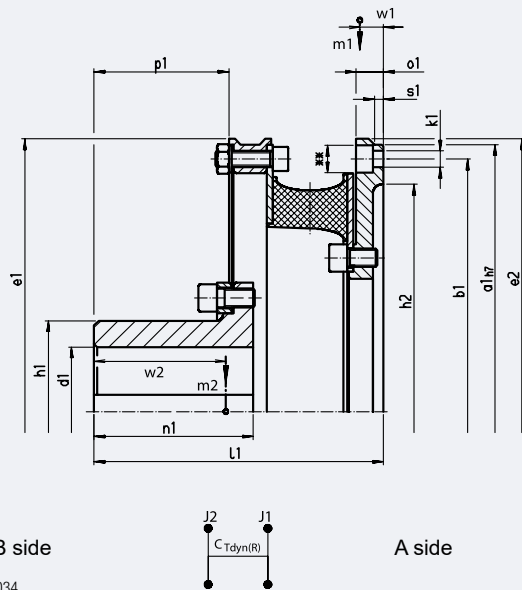

DD_886034

Figure 2

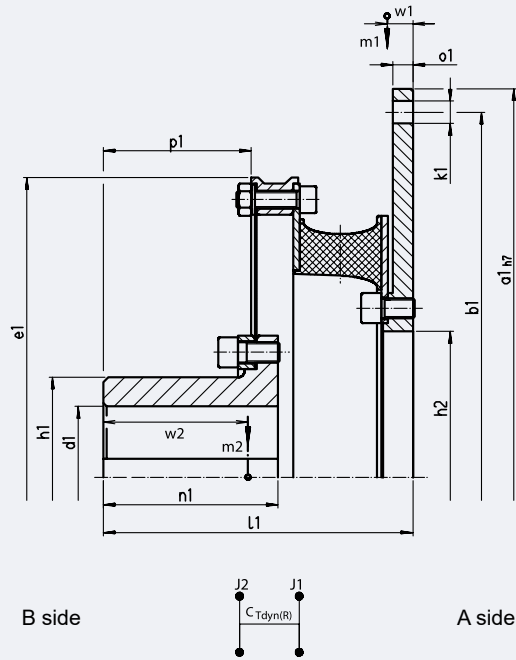

DD_886031

Coupling size		31		32		41		42		
Flywheel Connection to SAE J620		11,5"	14"	11,5"	14"	14"	16"	14"	16"	18"
Figure		1	2	1	2	1	2	1	2	2
Diameter mm	$d_{1\text{ vor}}$	30	30	30	30	35	35	35	35	35
	$d_{1\text{ max}}$	85	85	85	85	120	120	120	120	120
	a_1	352.4	466.7	352.4	466.7	466.7	517.5	466.7	517.5	571.5
	b_1	333.4	438.2	333.4	438.2	438.2	489	438.2	489	542.9
	e_1	360	360	360	360	475	475	475	475	475
	e_2	360	-	360	-	-	-	-	-	-
	h_1	120	120	120	120	168	168	168	168	168
	h_2	300	175	300	175	405	245	405	245	245
k_1	8xØ11**	8xØ13.5	8xØ11**	8xØ13.5	8xØ13.5**	8xØ13.5	8xØ13.5**	8xØ13.5	8xØ13.5	12xØ17.5
Lengths mm	l_1	191	186	191	186	195	188	195	188	188
	n_1	105	105	105	105	105	105	105	105	105
	p_1	89	89	89	89	83	83	83	83	83
	o_1	18	12	18	12	22	15	22	15	15
	s_1	6	-	6	-	-	-	-	-	-
	w_1	15.5	16	16	9	18	11.5	18.5	12	11.5
	w_2^*	87	87	87.5	87.5	84	84	84.5	84.5	84.5
	w_2^*	87	87	87.5	87.5	84	84	84.5	84.5	84.5
Masses kg	m_1	10.8	16.6	10.9	16.7	22.2	24.5	22.5	24.8	30.3
	m_2^*	13.4	13.4	13.5	13.5	27.9	27.9	28.2	28.2	28.2
Mass mom. of inertia kgm ²	J_1	0.216	0.474	0.220	0.478	0.770	0.939	0.780	0.950	1.354
	J_2^*	0.192	0.192	0.195	0.195	0.691	0.691	0.701	0.701	0.701

*) at max. bore diameter. Other coupling sizes on request

**) + countersunk for cyl. screws ISO 4762

Dimensions and construction subject to change

Series TEF...W – R

Figure 1

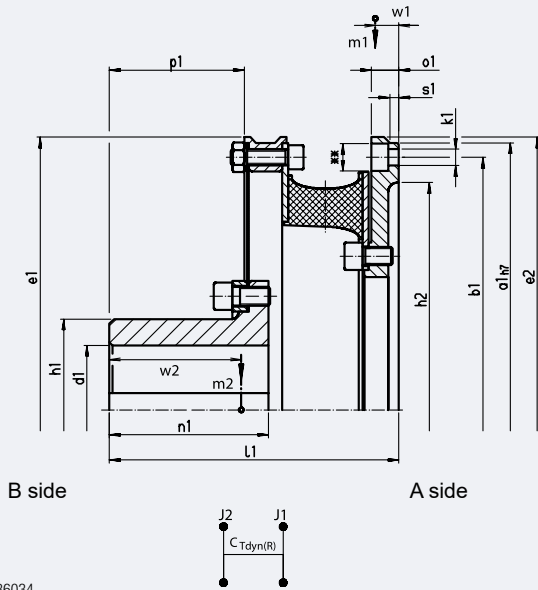

DD_-886034

Figure 2

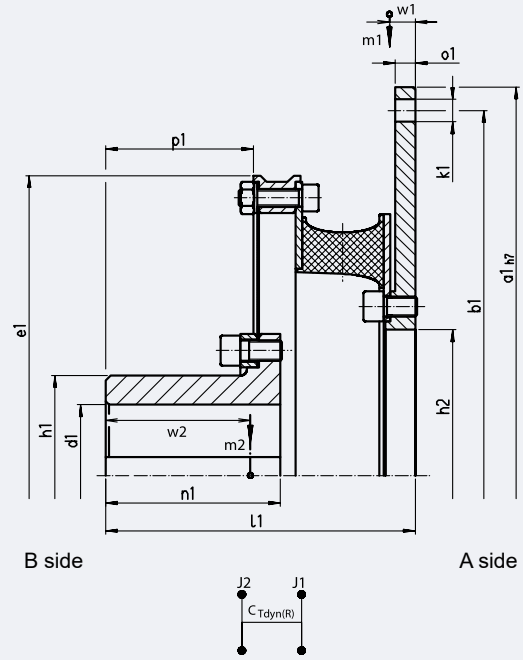

DD_-886031

Coupling size		43			51		52		
Flywheel Connection to SAE J620		14"	16"	18"	18"	21"	18"	21"	24"
Figure		1	2	2	1	2	1	2	2
Diameter mm	$d_{1\text{ vor}}$	35	35	35	55	55	55	55	55
	$d_{1\text{ max}}$	120	120	120	150	150	150	150	150
	a_1	466.7	517.5	571.5	571.5	673.1	571.5	673.1	733.4
	b_1	438.2	489	542.9	542.9	641.4	542.9	641.4	692.2
	e_1	475	475	475	608	608	608	608	608
	e_2	-	-	-	580	-	580	-	-
	h_1	168	168	168	210	210	210	210	210
	h_2	405	245	245	505	292	505	292	292
	k_1	8xØ13.5**	8xØ13.5	12xØ17.5	12xØ17.5**	12xØ17.5	12xØ17.5**	12xØ17.5	12xØ20
Lengths mm	l_1	195	188	188	289	279	272	262	262
	n_1	105	105	105	175	175	175	175	175
	p_1	83	83	83	146.5	146.5	146.5	146.5	146.5
	o_1	22	15	15	25	15	25	15	15
	s_1	-	-	-	7	-	7	-	-
	W_1	19	12.5	11.5	22	13	23	13.5	12.5
	W_2^*	85	85	85	142	142	134	134	134
Masses kg	m_1	22.7	25	30.5	38.2	44.4	39	45.2	53
	m_2^*	28.4	28.4	28.4	67.9	67.9	58.2	58.2	58.2
Mass mom. of inertia kgm ²	J_1	0.790	0.959	1.364	2.034	2.763	2.088	2.817	3.789
	J_2^*	0.711	0.711	0.711	2.751	2.751	2.025	2.025	2.025

*) at max. bore diameter. Other coupling sizes on request

**) + countersunk for cyl. screws ISO 4762

Dimensions and construction subject to change

Stromag – Flexible Couplings

TRI-R Highly-Flexible Ring Coupling

Series TEF...W – R

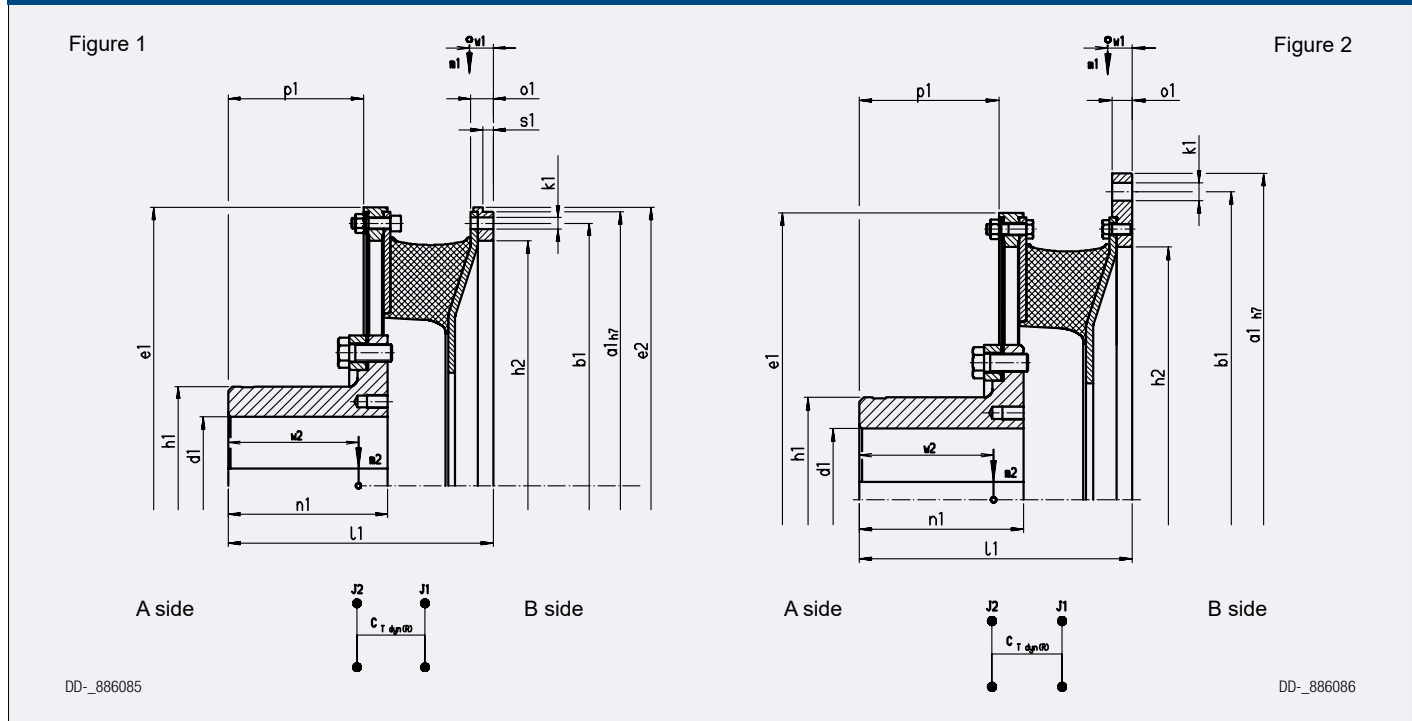

Coupling size		64				74		
Flywheel Connection to SAE J620		metr.	18"	21"	24"	metr.	21"	24"
Figure		1	2	2	2	1	1	2
Diameter mm	$d_{1\text{vor}}$	80	80	80	80	85	85	85
	$d_{1\text{max}}$	160	160	160	160	170	170	170
	a_1	635	571.5	673.1	733.4	680	673.1	733.4
	b_1	608	542.9	641.4	692.2	650	641.4	692.2
	e_1	645	645	645	645	692	692	692
	e_2	645	645	–	–	692	692	–
	h_1	230	230	230	230	240	240	240
	h_2	568	490	568	568	610	600	610
	k_1	32xØ13.5	12xØ17.5	12xØ17.5	12xØ20	32xØ15.5	12xØ17.5	12xØ20
Lengths mm	l_1	307	315	315	307	332	332	342
	n_1	185	185	185	185	200	200	200
	p_1	157	157	157	157	170	170	170
	o_1	26	15***	8.5**	23	28	28	10.5**
	s_1	12	8	–	–	12	12	–
	W_1	27.5	35.5	35	33	30	40	38
	W_2^*	151	145.5	145.5	145.5	165.5	159	159
Masses kg	m_1	28.3	46.2	45.9	39.2	34.9	41.2	60.9
	m_2^*	86.7	81.8	81.8	81.8	102.9	97.4	97.4
Mass mom. of inertia kgm ²	J_1	2.123	3.192	3.567	3.276	2.982	3.228	5.632
	J_2^*	3.317	3.164	3.164	3.164	4.614	4.426	4.426

*) at max. bore diameter. Other coupling sizes on request

**) + countersunk for cyl. screws ISO 4762

***) + countersunk for hexagon screw ISO 4017

Dimensions and construction subject to change

Series TEF...W – R

Figure 1

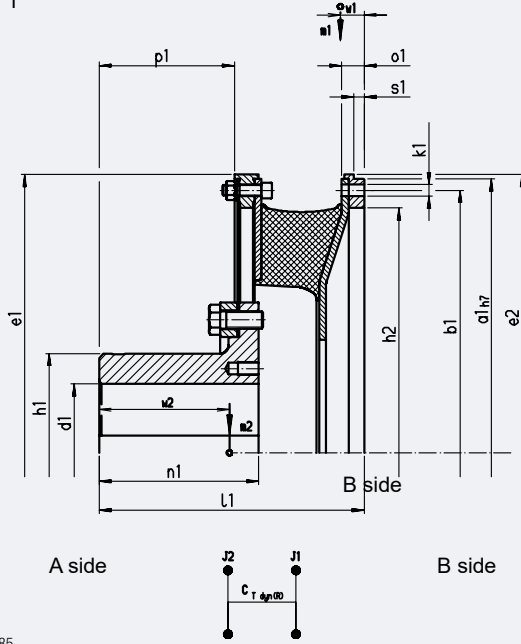

DD_-886085

Figure 2

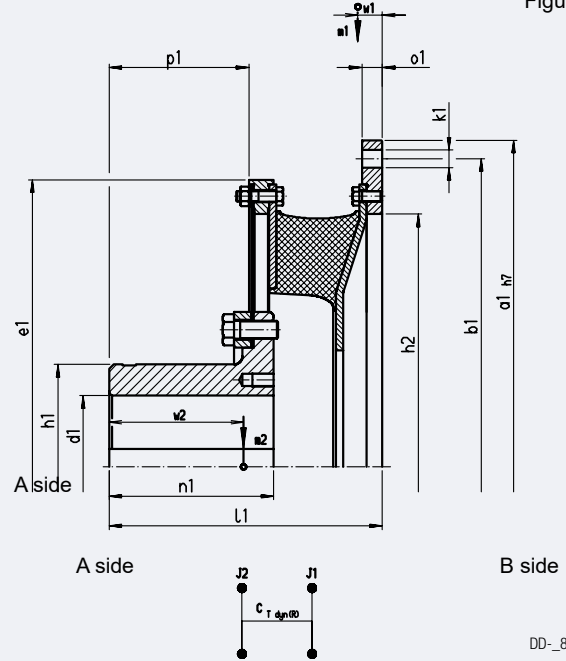

DD_-886086

Coupling size		84		94	104	114	124	
Flywheel Connection to SAE J620		metr.	24"	metr.	metr.	metr.	metr.	
Figure		1	1	1	1	1	1	
Diameter mm	$d_{1\text{ vor}}$	90	90	100	110	120	125	
	$d_{1\text{ max}}$	185	185	200	220	235	255	
	a_1	730	733.4	790	860	920	995	
	b_1	700	692.2	755	820	880	950	
	e_1	740	740	804	875	935	1010	
	e_2	740	740	804	875	935	–	
	h_1	260	260	280	308	330	358	
	h_2	655	655	706	765	820	905	
	k_1	32xØ15.5	12xØ20	32xØ17.5	32xØ20	32xØ20	32xØ21	
Lengths mm	l_1	367	367	385	413	451	355	
	n_1	225	225	235	250	275	315	
	p_1	192	192	198	210	231	167	
	o_1	30	30	32	33	37	12	
	s_1	14	14	15	17	18	12	
	w_1	43.5	43	46.5	49.5	58.0	33	
	w_2^*	177	177	185	198	219	183	
	Masses kg	m_1	48.4	48.8	59.9	74.0	104.3	84.0
		m_2^*	121.8	121.8	153.0	203.4	252.9	316.0
Mass mom. of inertia kgm ²	J_1	4.410	4.468	6.458	9.444	15.32	11.94	
	J_2^*	6.131	6.131	9.213	14.56	21.24	28.62	

*) at max. bore diameter. Other coupling sizes on request

**) + countersunk for cyl. screws ISO 4762

Dimensions and construction subject to change

Stromag – Flexible Couplings

TRI-R Highly-Flexible Ring Coupling

TEW...W – R Series

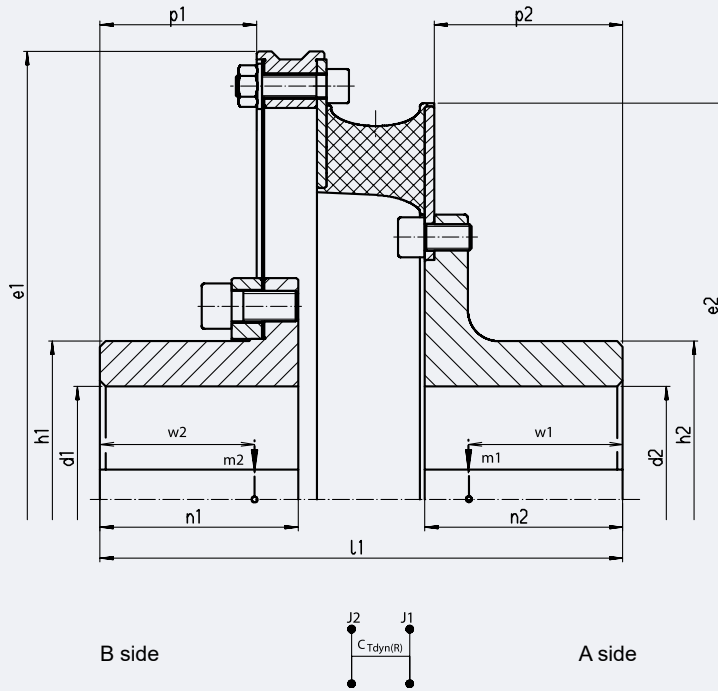

DD_886029

Coupling size		31	32	41	42	43	51	52
Diameter mm	$d_{1\text{ vor}}$	30	30	35	35	35	55	55
	$d_{1\text{ max}}$	85	85	120	120	120	150	150
	$d_{2\text{ vor}}$	30	30	35	35	35	55	55
	$d_{2\text{ max}}$	85	85	120	120	120	150	150
	e_1	360	360	475	475	475	608	608
	e_2	314	317	417	420	420	520	525
	h_1	120	120	168	168	168	210	210
	h_2	120	120	168	168	168	210	210
Lengths mm	l_1	272	272	277	277	277	432	432
	n_1	105	105	105	105	105	175	175
	n_2	105	105	105	105	105	175	175
	p_1	89	89	83	83	83	146.5	146.5
	p_2	101	101	100	100	100	169	169
	w_1^*	80	80.5	79.5	80.5	81	129.5	130.5
	w_2^*	87	87.5	87	87.5	88	142	141.5
	Masses kg	m_1^*	10.9	11	21.9	22.2	22.4	48.0
m_2^*		13.4	13.5	29.4	29.7	29.9	67.9	64.8
Mass mom. of inertia kgm ²	J_1^*	0.082	0.086	0.306	0.317	0.326	0.968	1.022
	J_2^*	0.192	0.195	0.763	0.774	0.783	2.751	2.553

*) at max. bore diameter. Other coupling sizes on request
Dimensions and construction subject to change

Series TEW...W – R

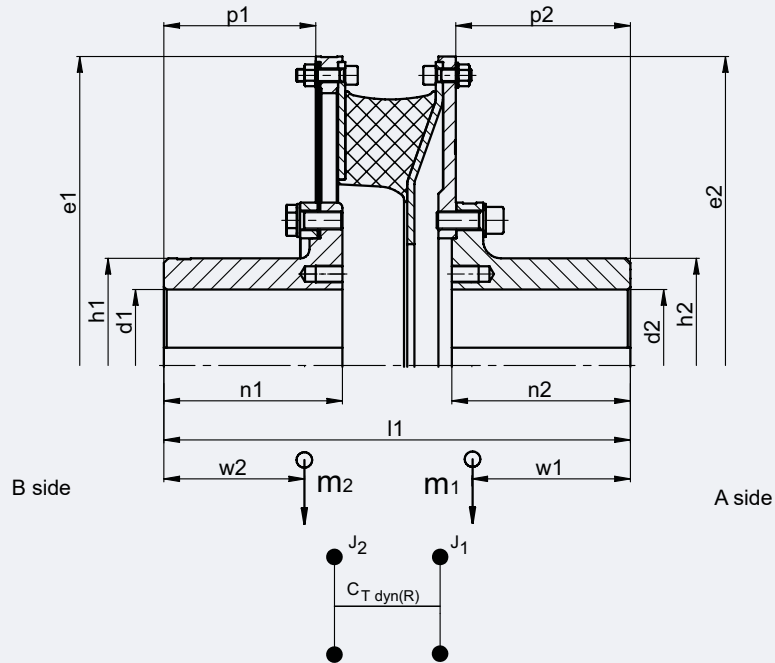

998-01519

Coupling size		64	74	84	94	104	114	124
Diameter mm	$d_{1\text{vor}}$	80	85	90	100	110	120	125
	$d_{1\text{max}}$	160	170	185	200	220	235	255
	$d_{2\text{vor}}$	80	85	90	100	110	120	125
	$d_{2\text{max}}$	160	170	185	200	220	235	255
	e_1	645	692	740	804	875	935	1010
	e_2	645	692	740	804	875	935	1010
	h_1	230	240	260	280	308	330	358
	h_2	230	240	260	280	308	330	358
Lengths mm	l_1	484	522,5	582	610	655	720	661
	n_1	185	200	225	235	250	275	315
	n_2	185	200	225	235	250	275	290
	p_1	157	170	192	198	210	231	167
	p_2	180,5	195,5	219,5	229,5	244,5	268,5	283,5
	w_1^*	163,5	177,5	199,5	209,5	223,5	249	255
	w_2^*	144	157,5	175	183	183	213,5	182,5
	Masses kg	m_1^*	97,4	120,8	151,7	190,3	253,7	330,1
m_2^*		82,6	99,4	123,9	156,6	207,6	248,9	324,1
Mass mom. of inertia kgm ²	J_1^*	3,929	5,534	8,074	12,057	19,023	28,99	37,74
	J_2^*	3,246	4,617	6,337	9,614	15,344	20,641	30,545

*) at max. bore diameter. Other coupling sizes on request
Dimensions and construction subject to change

Stromag – Flexible Couplings

TRI-R Highly-Flexible Ring Coupling

TEF...W – RR Series

Figure 1

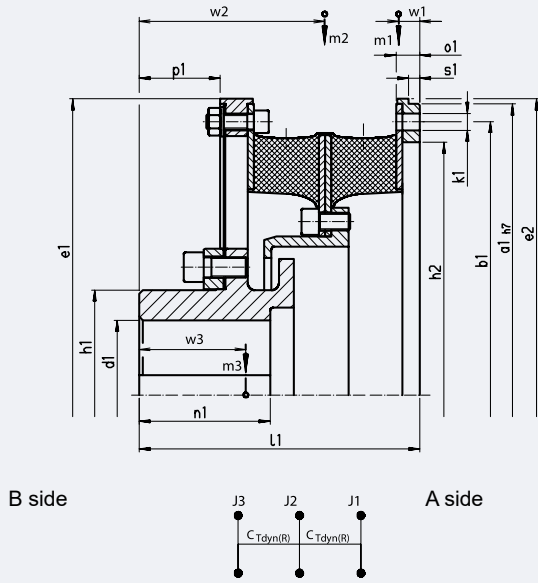
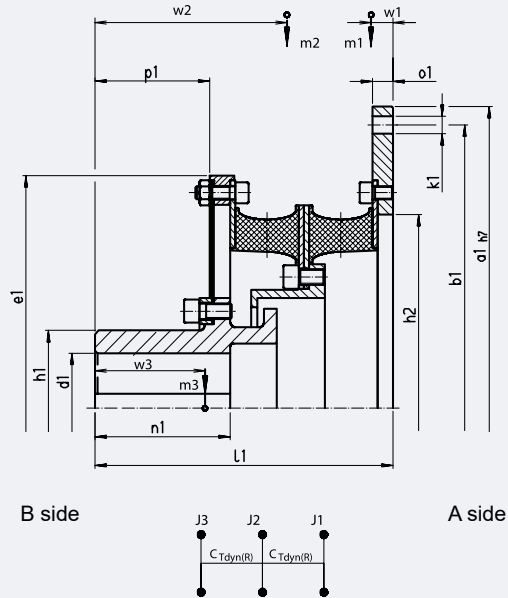

Figure 2



DD_-886032

DD_-886035

Coupling size		31		32		41		42		
Flywheel Connection to SAE J620		11,5"	14"	11,5"	14"	14"	16"	14"	16"	18"
Figure		1	2	1	2	1	2	1	2	2
Diameter mm	$d_{1\text{ vor}}$	30	30	30	30	35	35	35	35	35
	$d_{1\text{ max}}$	85	85	85	85	120	120	120	120	120
	a_1	352.4	466.7	352.4	466.7	466.7	517.5	466.7	517.5	571.5
	b_1	333.4	438.2	333.4	438.2	438.2	489	438.2	489	542.9
	e_1	360	360	360	360	475	475	475	475	475
	e_2	360	-	360	-	475	-	475	-	-
	h_1	120	120	120	120	168	168	168	168	168
	h_2	300	300	300	300	405	405	405	405	405
k_1	8xØ11	8xØ13.5	8xØ11	8xØ13.5	8xØ13.5	8xØ13.5	8xØ13.5	8xØ13.5	8xØ13.5	12xØ17.5
Lengths mm	l_1	231	231	231	231	225	225	225	225	225
	n_1	105	105	105	105	105	105	105	105	105
	p_1	89	89	89	89	65	65	65	65	65
	o_1	16	16	16	16	19	18	19	18	18
	s_1	8	-	8	-	9	-	9	-	-
	W_1	13.5	10	19.5	10.5	15.5	13	16.5	13.5	12.5
	W_2^*	160	160	160.5	160.5	147	147	147	147	147
W_3^*	88.5	88.5	89	89	74.5	74.5	75	75	75	
Masses kg	m_1	5.1	14	5.2	14.2	9.7	14.8	10	15.1	21.6
	m_2	7.6	7.6	7.9	7.9	14.9	14.9	15.5	15.5	15.5
	m_3^*	14	14	14.1	14.1	29.3	29.3	29.6	29.6	29.6
Mass mom. of inertia kgm ²	J_1	0.126	0.512	0.129	0.516	0.424	0.734	0.435	0.745	1.230
	J_2	0.106	0.106	0.114	0.114	0.374	0.374	0.395	0.395	0.395
	J_3^*	0.167	0.167	0.171	0.171	0.661	0.661	0.672	0.672	0.672

*) at max. bore diameter. Other coupling sizes on request
Dimensions and construction subject to change

TEF...W – RR Series

Figure 1

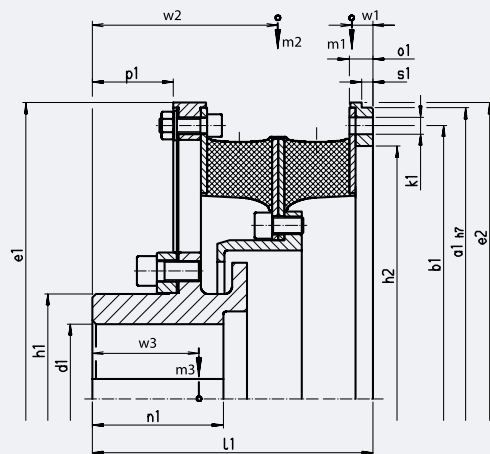

B side

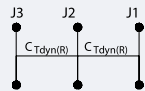

A side

DD_886032

Figure 2

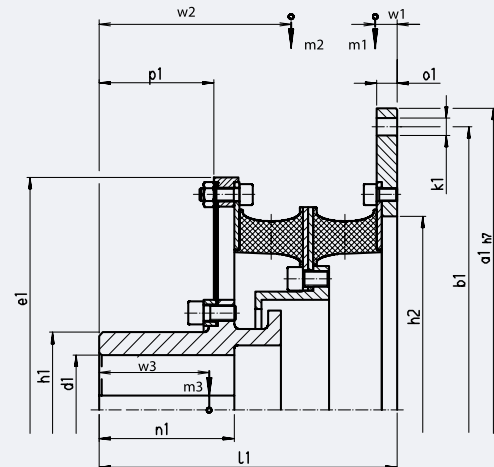

B side

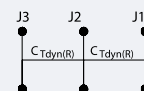

A side

DD_886035

Coupling size		43			51		52		
Flywheel Connection to SAE J620		14"	16"	18"	18"	21"	18"	21"	24"
Figure		1	2	2	1	2	1	1	2
Diameter mm	$d_{1\text{vor}}$	35	35	35	55	55	55	55	55
	$d_{1\text{max}}$	120	120	120	150	150	150	150	150
	a_1	466.7	517.5	571.5	571.5	673.1	571.5	673.1	733.4
	b_1	438.2	489	542.9	542.9	641.4	542.9	641.4	692.2
	e_1	475	475	475	608	608	608	608	608
	e_2	475	-	-	580	-	608	683	-
	h_1	168	168	168	210	210	210	210	210
	h_2	405	405	405	505	514	505	600	542
Lengths mm	k_1	8xØ13.5	8xØ13.5	12xØ17.5	12xØ17.5	12xØ17.5	12xØ17.5**	12xØ17.5	12xØ20
	l_1	225	225	225	289	291	287	272	274
	n_1	105	105	105	175	175	175	175	175
	p_1	65	65	65	77.5	77.5	77.5	77.5	77.5
	o_1	19	18	18	24	25	15.5	24	25
	s_1	9	-	-	10	-	8	10	-
	w_1	17	14	12.5	22	18	29.5	15	17.5
	w_2	147	147	147	192.5	192.5	177.5	177.5	177.5
w_3^*	75	75	75	98.5	98.5	95	95	95	
Masses kg	m_1	10.2	15.3	21.8	18.5	36.9	32	26.7	47.4
	m_2	15.9	15.9	15.9	29.7	29.7	29.9	29.9	29.9
	m_3^*	29.8	29.8	29.8	70	70	60.2	60.2	60.2
Mass mom. of inertia kgm ²	J_1	0.442	0.754	1.239	1.191	3.016	2.257	2.242	4.452
	J_2	0.414	0.414	0.414	1.148	1.148	1.227	1.227	1.227
	J_3^*	0.681	0.681	0.681	2.777	2.777	2.052	2.052	2.052

*) at max. bore diameter. Other coupling sizes on request

**) + countersunk for cyl. screws ISO 4762

Dimensions and construction subject to change

Stromag – Flexible Couplings

TRI-R Highly-Flexible Ring Coupling

TEF...W – RR Series

Figure 1

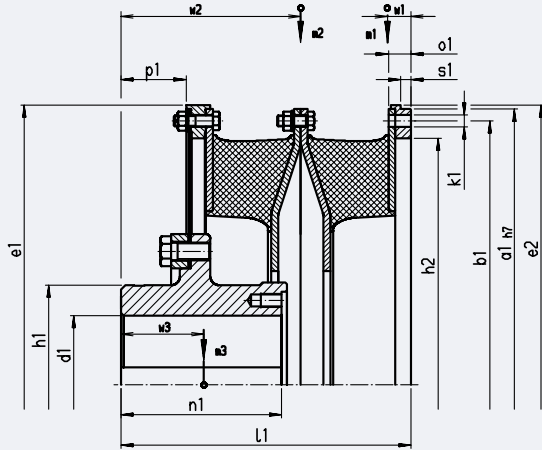

B side

A side

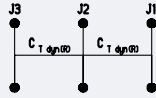

DD_886087

Figure 2

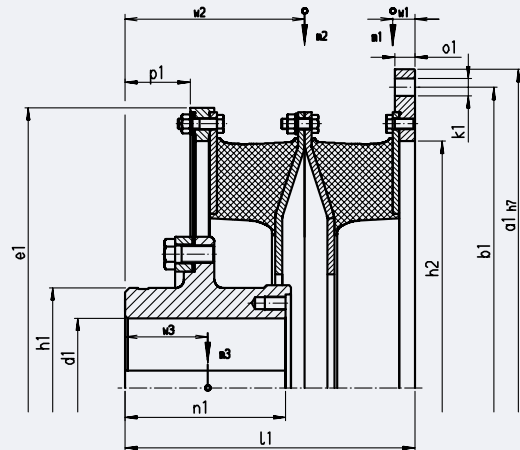

B side

A side

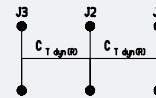

DD_886088

Coupling size		64				74		
Flywheel Connection to SAE J620		metr.	18"	21"	24"	metr.	21"	24"
Figure		1	2	2	2	1	1	2
Diameter mm	$d_{1\text{vor}}$	80	80	80	80	85	85	85
	$d_{1\text{max}}$	160	160	160	160	170	170	170
	a_1	635	571.5	673.1	733.4	680	673.1	733.4
	b_1	608	542.9	641.4	692.2	650	641.4	692.2
	e_1	645	645	645	645	692	692	692
	e_2	645	645	-	-	692	692	-
	h_1	230	230	230	230	240	240	240
	h_2	568	490	568	568	610	600	610
	k_1	32xØ13.5	12xØ17.5	12xØ17.5	12xØ20	32xØ15.5	12xØ17.5	12xØ20
Lengths mm	l_1	334	342	342	334	359	359	369
	n_1	185	185	185	185	200	200	200
	p_1	75	75	75	75	80	80	80
	o_1	26	15**	8.5**	23	28	28	10.5**
	s_1	12	8	-	-	12	12	-
	w_1	27.5	28.5	28	25.5	30	40	30
	w_2	207	207	207	207	222	212.5	222
	w_3^*	95.5	95.5	95.5	95.5	103	103	103
Masses kg	m_1	28.3	41.3	42.3	34.3	34.9	41.2	55.4
	m_2	46.8	46.8	46.8	46.8	55.8	50.3	55.8
	m_3^*	82.8	82.8	82.8	82.8	99.2	99.2	99.2
Mass mom. of inertia kgm ²	J_1	2.123	3.039	3.566	3.124	2.952	3.228	5.444
	J_2	2.750	2.750	2.750	2.750	3.707	3.519	3.707
	J_3^*	3.178	3.178	3.178	3.178	4.453	4.453	4.453

*) at max. bore diameter. Other coupling sizes on request

***) + countersunk for cyl. screws ISO 4762

Dimensions and construction subject to change

TEF...W – RR Series

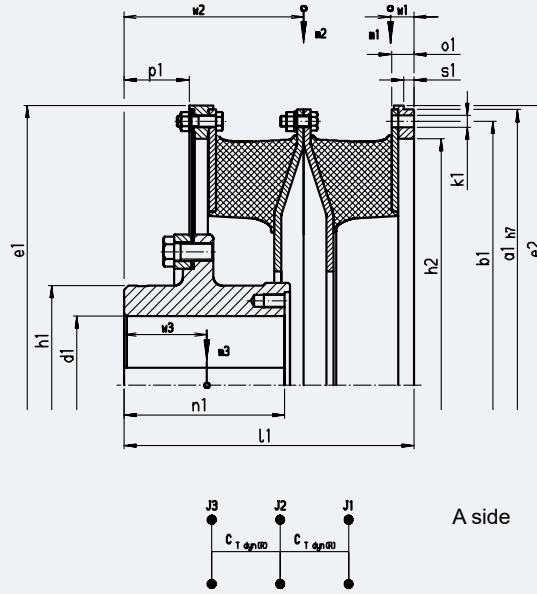

DD_886087

Coupling size		84		94		104		114		124	
Flywheel Connection to SAE J620		metr.		24"		metr.		metr.		metr.	
Figure		1		1		1		1		1	
Diameter mm	$d_{1\text{vor}}$	90		100		110		120		125	
	$d_{1\text{max}}$	185		200		220		235		255	
	a_1	730		790		860		920		995	
	b_1	700		755		820		880		950	
	e_1	740		804		875		935		1010	
	e_2	740		804		875		935		-	
	h_1	260		280		308		330		358	
	h_2	655		706		765		820		905	
Lengths mm	k_1	32xØ15.5		12xØ20		32xØ17.5		32xØ20		32xØ21	
	l_1	396		419		457		492		417	
	n_1	225		235		250		275		315	
	p_1	95		98		106		112		73	
	o_1	30		32		35		37		12	
	s_1	14		15		17		18		12	
	w_1	33		35		37.5		45		33	
	w_2	248		261		284		305		265	
Masses kg	w_3^*	118.5		123		132		144.5		127	
	m_1	42.0		52.8		71.2		92.3		84.0	
	m_2	66.2		78.7		96.3		145.5		187.0	
Mass mom. of inertia kgm ²	m_3^*	125.1		156.2		207.2		257.9		318.0	
	J_1	4.141		6.129		9.697		14.56		11.94	
	J_2^*	5.114		7.086		10.22		18.53		24.79	
	J_3^*	6.192		9.280		14.75		21.38		28.67	

*) at max. bore diameter. Other coupling sizes on request

**) + countersunk for cyl. screws ISO 4762

Dimensions and construction subject to change

Stromag – Flexible Couplings

TRI-R Highly-Flexible Ring Coupling

TEW...W – RR Series

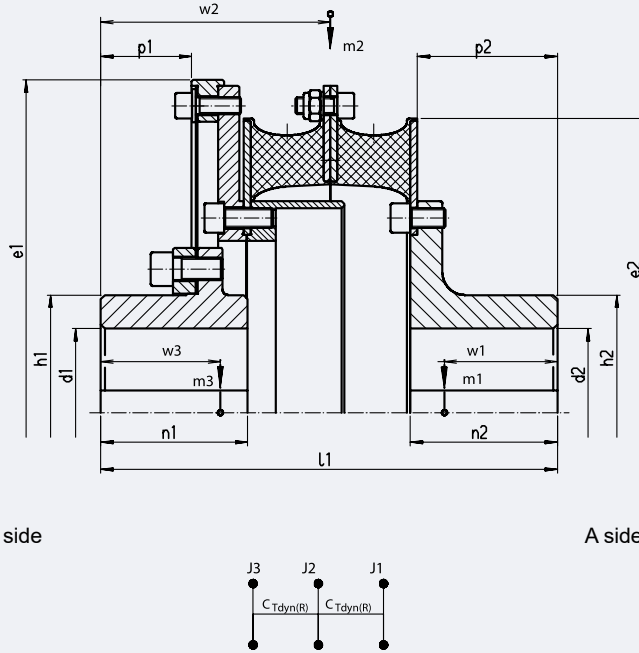

DD_886030

Coupling size		31	32	41	42	43	51	52
Diameter mm	$d_{1\text{ vor}}$	30	30	35	35	35	55	55
	$d_{1\text{ max}}$	85	85	120	120	120	150	150
	$d_{2\text{ vor}}$	30	30	35	35	35	55	55
	$d_{2\text{ max}}$	85	85	120	120	120	150	150
	e_1	360	360	475	475	475	608	608
	e_2	314	317	417	420	420	520	525
	h_1	120	120	168	168	168	210	210
	h_2	120	120	168	168	168	210	210
Lengths mm	l_1	287	287	326	326	326	450	450
	n_1	105	105	105	105	105	175	175
	n_2	105	105	105	105	105	175	175
	p_1	77	77	65	65	65	82.5	82.5
	p_2	68	68	100	100	100	169	169
	w_1^*	61.5	62	79.5	80.5	81	129.5	131
	w_2^*	162	162	164	164	164	204	204
	w_3^*	90.5	90.5	85	85.5	85.5	109	109.5
Masses kg	m_1^*	11.0	11.2	21.9	22.2	22.4	48.0	48.8
	m_2^*	4.6	4.9	9.2	9.8	10.2	19.5	23.4
	m_3^*	21.9	22.0	46.4	46.7	46.9	98.1	98.9
Mass mom. of inertia kgm ²	J_1^*	0.083	0.087	0.306	0.317	0.326	0.968	1.023
	J_2^*	0.099	0.106	0.352	0.373	0.392	1.097	1.402
	J_3^*	0.304	0.308	1.180	1.191	1.200	3.785	3.840

*) at max. bore diameter. Other coupling sizes on request
Dimensions and construction subject to change

TEW...W – RR Series

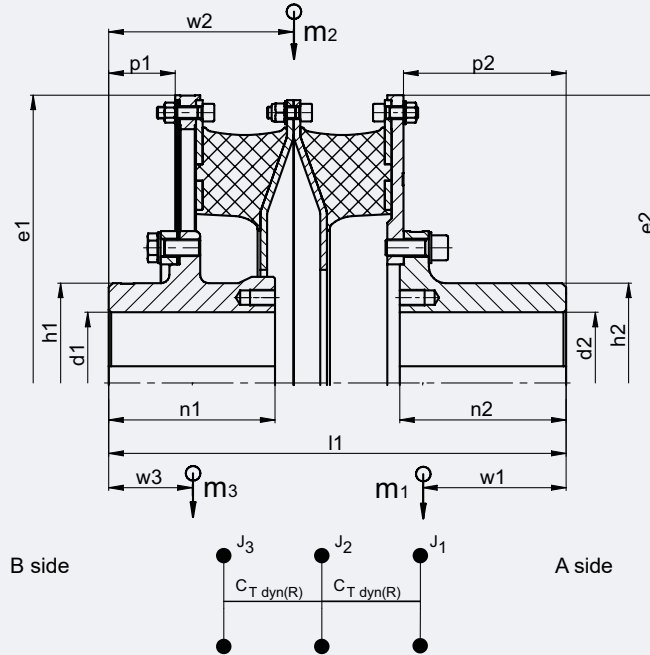

998-01520

Coupling size		64	74	84	94	104	114	124
Diameter mm	$d_{1 \text{ vor}}$	80	85	90	100	110	120	125
	$d_{1 \text{ max}}$	160	170	185	200	220	235	255
	$d_{2 \text{ vor}}$	80	85	90	100	110	120	125
	$d_{2 \text{ max}}$	160	170	185	200	220	235	255
	e_1	645	692	740	804	875	935	1010
	e_2	645	692	740	804	875	935	1010
	h_2	230	240	260	280	308	330	358
Lengths mm	l_1	511	550	611	644	699	761	723
	n_1	185	200	225	235	250	275	315
	n_2	185	200	225	235	250	275	290
	p_1	75	80	95	98	106	112	73
	p_2	180.5	195.5	219.5	229.5	244.5	268.5	283.5
	w_1^*	158	172.5	193	203.5	225	242	255
	w_2	207	222	248	260.5	283.5	304.5	265
	w_3^*	93	100.5	116	119.5	128	139	123
Masses kg	m_1^*	91.4	114.5	144.6	181.4	248.3	315.3	383
	m_2	48.9	60.2	69.4	83.4	103.5	140	193.7
	m_3^*	83.6	100.8	126.7	160.2	211.2	254.4	322
Mass mom. of inertia kgm ²	J_1^*	3.712	5.297	7.702	11.528	18.944	27.814	37.74
	J_2	2.942	4.171	5.518	7.864	11.438	17.671	26.523
	J_3^*	3.259	4.594	6.394	9.687	15.435	20.801	29.976

*) at max. bore diameter. Other coupling sizes on request
Dimensions and construction subject to change

Stromag – Flexible Couplings

TRI-R Highly-Flexible Ring Coupling

Characteristics

T_{KN}	
The coupling's nominal torque can be permanently transferred over the whole permitted speed range. It must be higher than the system's nominal torque T_N .	$T_{KN} \geq T_N$
T_{Kmax1}	
The coupling's max torque T_{Kmax1} can be endured as a peak load and may not be exceeded by peak torques T_{max1} when the system is operating in normal, nonstationary mode. A system's normal nonstationary modes are unavoidable and occur repeatedly (e.g. starting/stopping, resonance passes, switchovers, accelerations, etc.).	$T_{Kmax1} \geq T_{max1}$
T_{Kmax2}	
The coupling's max torque T_{Kmax2} can be endured as a peak load and may not be exceeded by peak torques T_{max2} when the system is operating in anomalous, nonstationary mode. A system's anomalous, nonstationary modes are avoidable and are not part of the planned operating scheme (e.g. emergency stops, sync failure, short circuits, etc.) Overloading the Stromag TRI-R coupling with peak torques T_{max2} in a system's anomalous nonstationary mode shortens the service life and is tolerated in individual cases.	$T_{Kmax2} \geq T_{max2}$
T_{Kw}	
The admissible permanent alternating torque describes the amplitude of the max permanent periodic torque variation. This torque may be superimposed on a base load equal to T_{KN} . This requires in addition an analysis of the max damping power P_{KV} .	
ΔK_a	
Max axial displacement of the coupling. The shaft's axial displacement ΔW_a must be less than ΔK_a .	$\Delta K_a \geq \Delta W_a$
ΔK_r	
Max radial displacement of the coupling. The shaft's radial displacement ΔW_r must be less than ΔK_r .	$\Delta K_r \geq \Delta W_r$
The values of ΔK_r for the Stromag TRI-R coupling refer to coupling shaft speeds up to 600 rpm. The conversion to other speeds is made by the equation	$\Delta K_r(n) = \sqrt{\frac{600 \text{ min}^{-1}}{n}} \cdot \Delta K_r$
With ambient temperatures higher than 30°C, the admissible radial offset must be reduced by the temperature factor $S_{\theta Kr}$.	$\Delta K_r(T_U) = \frac{\Delta K_r}{S_{\theta Kr}}$
ΔK_w	
Max angular displacement of the coupling. The shaft's angular displacement ΔW_w must be less than ΔK_w . A ΔK_w value of 0.5° is permitted for TRI-R couplings. This value, however, may be utilized to the full only when there are no other options for shaft displacement.	$\Delta K_w \geq \Delta W_w$

F_a
The axial reaction force of the diaphragm is stated for an offset of 1 mm. Steel diaphragms have a progressive characteristic. Formulas for the calculation of larger axial offsets on request.

C_r
The radial stiffness represents the ratio of radial reaction force to radial displacement. The specified values apply to the coupling at operating temperature, with a surface temperature of about 30°C.

C_{Tdyn}	
The dynamic torsional spring stiffness represents the ratio of torque amplitude to torque angle during an oscillation. The torque amplitude is superimposed on an initial load (coupling torque). Stromag TRI-R coupling's C _{Tdyn} value remains constant over the coupling torque (linear characteristic curve), but changes with the amplitude, frequency, and temperature of the flexible element. The specified nominal values for C _{Tdyn} are based on a coupling torque of 0.8 • T _{KN'} , an alternating torque of 0.2 • T _{KN'} , and a frequency of 10 Hz on a coupling at operating temperature, with a surface temperature of about 30°C.	$C_{Tdyn} = \frac{T_{el}}{\varphi_w}$
C_{Tdyn warm} takes into account that high power dissipation causes the coupling to heat up.	$C_{Tdyn\ warm} = 0,7 \cdot C_{Tdyn}$
C_{Tdyn A} takes into account the effects of a small alternating torque amplitude.	$C_{Tdyn\ A} = 1,35 \cdot C_{Tdyn}$
Calculations of torsional vibrations in the system are recommended to include C _{Tdyn warm} (0,7), und C _{Tdyn A} (1,35)	

Ψ	
The relative damping is a factor for the capacity of a coupling to convert a part of the occurring cyclic energy into heat. The damping can be determined by the damping loop (hysteresis loop). The area A _D is a factor for the damping work W _D during a vibration cycle. The area A _{el} represents the work done in deflection W _{el} at a given load. The specified nominal values for Ψ are based on a coupling torque of 0.8 • T _{KN'} , an alternating torque of 0.2 • T _{KN'} , and a frequency of 10 Hz on a coupling at operating temperature, with a surface temperature of about 30°C.	$\Psi = \frac{W_D}{W_{el}} = \frac{A_D}{A_{el}}$

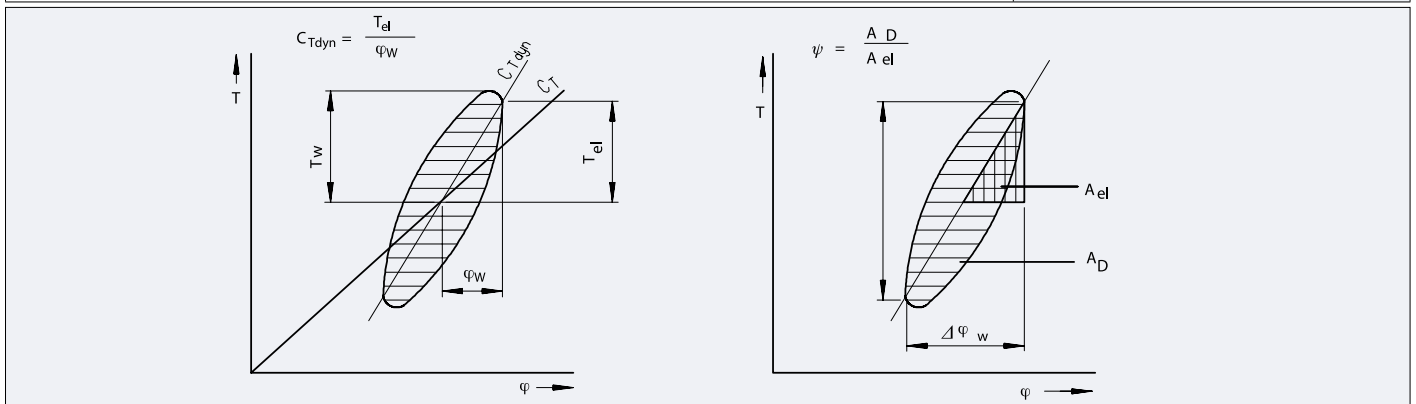

Stromag – Flexible Couplings

TRI-R Highly-Flexible Ring Coupling

Characteristics

P_{KV}

The admissible damping power indicates how much damping (heat) the coupling can permanently absorb resp. dissipate. The sum of the damping power of each vibration order (i.e. ΣP_{vi}) must be less than the damping power of the coupling.

$$P_{vi} = \frac{\pi}{\sqrt{\left(\frac{2\pi}{\Psi}\right)^2 + 1}} \cdot \frac{T_{wi}^2 \cdot f_i}{C_{tdyn}}$$

$$P_{KV} \geq \Sigma P_{vi}$$

The stated value P_{KV60} describes the damping power which can be absorbed over the period of 1 hour. To determine the damping power which can be permanently absorbed ($P_{KV\infty}$), the value P_{KV60} has to be multiplied by the factor 0.5. With an ambient temperature T_U higher than 30°C, the admissible damping power must be reduced by the temperature factor S_{PKV} .

$$P_{KV}(T_U) = \frac{P_{KV}}{S_{\text{PKV}}}$$

Temperature factors S_{Kr} und S_{PKV}

Temperature factors shall take into consideration the reduction of the physical characteristics of rubber-flexible material caused by heating.

The coupling temperature is determined by the ambient temperature plus an internal heating caused by internal material friction in the rubber volume, resulting from alternating torques and alternating loads due to shaft offsets.

With higher ambient temperatures the coupling characteristic values Δ_{Kr} and P_{KV} must be reduced through the corresponding temperature factors S_{PKV} and S_{Kr} .

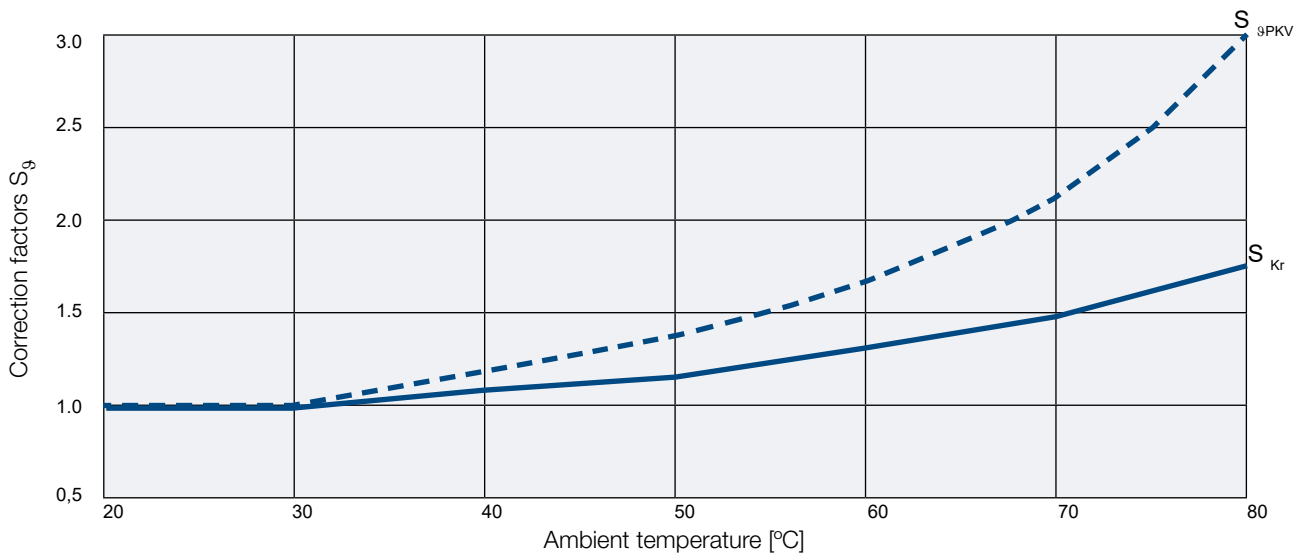

Driving machine		
Engine system (electric motor, combustion engine etc.)		
Engine type (make, type)		
Engine mounting (rigid or resilient)		
SAE housing of engine		
Flywheel centering diameter		mm
Nominal output		kW
Nominal speed		rpm
Speed range		rpm
Nominal torque		Nm
Max. torque (max. breakdown torque)		Nm
Mass moment of inertia		kgm ²
Number of starts resp. reversing processes per hour		
Gear		
Reduction		
Mass moment of inertia		kgm ²
Driving machine		
System (generator, fan, compressor, fixed- or controllable pitch propeller)		
Main or auxiliary drive		
Type of construction (self-supporting or flange-type connected)		
Mass moment of inertia		kgm ²
Coupling		
Assembly site in the driving line (provide a principle sketch)		
Bore dimensions for the coupling hub		mm
Ambient temperature		°C, °K
Classification society		
Type of vessel		
Ice class		

Stromag – Flexible Couplings

TRI-R Highly-Flexible Ring Coupling

Use in potentially explosive environments, question sheet

Applications		<input type="radio"/>	Group II (above ground)
Potentially explosive atmosphere of air and		<input type="radio"/>	gas
		<input type="radio"/>	dust
Zone (Category)	gas	<input type="radio"/>	zone 1 (Category 2G)
		<input type="radio"/>	zone 2 (Category 3G)
	dust	<input type="radio"/>	zone 22 not electrically conducting (Category 3D)
Temperature category in atmosphere with gas	gas	<input type="radio"/>	T1
		<input type="radio"/>	T2
		<input type="radio"/>	T3
		<input type="radio"/>	T4
Max surface temperature	dust	<input type="radio"/>	125°C
		<input type="radio"/>	< 120°C
		<input type="radio"/>	-20°C to +40°C
Ambient temperature		<input type="radio"/>	other ambient temperatures only with certain restrictions



Premier Industrial Company Leading Brands

OTHER PRODUCT SOLUTIONS FROM **ALTRA MOTION**

Our comprehensive product offerings include various types of clutches and brakes, overrunning clutches, engineered bearing assemblies, gearing and gear motors along with linear motion products, belted drives, couplings, limit switches, precision motors, drives & controls, miniature motors and engine braking systems. With thousands of product solutions available, Altra provides true single source convenience while meeting specific customer requirements. Many major OEMs and end users prefer Altra products as their No. 1 choice for performance and reliability.

WWW.ALTRAMOTION.COM



Electric Clutches & Brakes

Inertia Dynamics
Matrix
Stromag
Warner Electric



Precision Motors & Automation

Kollmorgen



Heavy Duty Clutches & Brakes

Industrial Clutch
Stromag
Svendborg Brakes
Twiflex
Wichita Clutch



Miniature Motors

Portescap



Overrunning Clutches

Formsprag Clutch
Marland Clutch
Stieber



Linear Systems

Thomson



Engineered Couplings & Universal Joints

Ameridrives
Bibby Turboflex
Guardian Couplings
Huco
Lamiflex Couplings
Stromag
TB Wood's



Engine Braking Systems

Jacobs Vehicle Systems



Gear Drives & Gear Motors

Bauer Gear Motor
Boston Gear
Delroyd Worm Gear
Nuttall Gear



Specialty Components

Kilian
Stromag
TB Wood's

Stromag Facilities

Europe

Germany

Hansastraße 120
59425 Unna - Germany
+49 (0) 23 03 102 0

*Clutches & Brakes, Couplings,
Geared Cam Limit Switches, Discs*

Dessauer Str. 10
06844 Dessau-Roßlau - Germany
+49 (0) 340 2190 0

Electromagnetic Clutches & Brakes

France

Avenue de l'Europe
18150 La Guerche sur L'Aubois - France
+33 (0)2 48 80 72 72

Disc Brakes & Drum Brakes

Great Britain

Amphill Road
Bedford, MK42 9RD - UK
+44 (0)1234 324347

*Electromagnetic Clutches & Brakes,
Industrial Caliper Brakes*

North America

USA

31 Industrial Park Road
New Hartford, CT 06057 - USA
860-238-4783

Electromagnetic Clutches & Brakes

300 Indiana Highway 212
Michigan City, IN 46360 - USA
219-874-5248

Couplings

2800 Fisher Rd.
Wichita Falls, TX 76302 - USA
940-723-3400

*Geared Cam Limit Switches,
Industrial Caliper & Drum Brakes*

South America

Brasil

Avenida João Paulo Ablas, 2970
Jardim da Glória, Cotia - SP,
06711-250 - Brasil
+55 (11) 4615-6300

*Flexible Couplings, Bearing
Isolators, and Coupling Guards*

Asia Pacific

China

T40B -5, No. 1765 Chuan Qiao Road
Pudong 201206, Shanghai - China
Tel +86 21-60580600

*Clutches & Brakes, Electromagnetic
Clutches & Brakes, Couplings, Industrial
Caliper & Drum Brakes, Discs, Geared
Cam Limit Switches*

India

Gat No.: 448/14, Shinde Vasti, Nighoje
Tal Khed, Pune- 410 501
+91 2135 622100

*Clutches & Brakes, Electromagnetic
Clutches & Brakes, Couplings, Industrial
Caliper & Drum Brakes, Discs, Geared
Cam Limit Switches, Wind Brakes*

Altra Renewable Energy

Denmark

Jernbanevej 9
5882 Vejstrup
+45 63 255 255

Wind Brakes

The Brands of Altra Motion

Couplings

Ameridrives
www.ameridrives.com

Bibby Turboflex
www.bibbyturboflex.com

Guardian Couplings
www.guardiancouplings.com

Huco
www.huco.com

Lamiflex Couplings
www.lamiflexcouplings.com

Stromag
www.stromag.com

TB Wood's
www.tbwoods.com

Linear Systems

Thomson
www.thomsonlinear.com

Geared Cam Limit Switches

Stromag
www.stromag.com

Engineered Bearing Assemblies

Kilian
www.kilianbearings.com

Electric Clutches & Brakes

Matrix
www.matrix-international.com

Stromag
www.stromag.com

Warner Electric
www.warnerelectric.com

Belted Drives

TB Wood's
www.tbwoods.com

Heavy Duty Clutches & Brakes

Twiflex
www.twiflex.com

Stromag
www.stromag.com

Svendborg Brakes
www.svendborg-brakes.com

Wichita Clutch
www.wichitaclutch.com

Gearing & Specialty Components

Bauer Gear Motor
www.bauergears.com

Boston Gear
www.bostongear.com

Delevan
www.delevan.com

Delroyd Worm Gear
www.delroyd.com

Nuttall Gear
www.nuttallgear.com

Engine Braking Systems

Jacobs Vehicle Systems
www.jacobsvehiclesystems.com

Precision Motors & Automation

Kollmorgen
www.kollmorgen.com

Miniature Motors

Portescap
www.portescap.com

Overrunning Clutches

Formsprag Clutch
www.formsprag.com

Marland Clutch
www.marland.com

Stieber
www.stieberclutch.com

Neither the accuracy nor completeness of the information contained in this publication is guaranteed by the company and may be subject to change in its sole discretion. The operating and performance characteristics of these products may vary depending on the application, installation, operating conditions and environmental factors. The company's terms and conditions of sale can be viewed at <http://www.altramotion.com/terms-and-conditions/sales-terms-and-conditions>. These terms and conditions apply to any person who may buy, acquire or use a product referred to herein, including any person who buys from a licensed distributor of these branded products.

©2021 by Stromag LLC. All rights reserved. All trademarks in this publication are the sole and exclusive property of Stromag LLC or one of its affiliated companies.